

PROCESS DYNAMICS AND CONTROL

CHBE320, Fall 2021

Professor Dae Ryook Yang

Dept. of Chemical & Biological Engineering

Korea University

Objectives of the Class

- **What is process control?**
- **Basics of process control**
- **Basic hardware and instrumentation**
- **Process modeling (dynamics)**
- **Analysis of dynamic systems**
- **Design of feedback controllers**
- **Various Control strategies**
- **Other advanced topics**

- **JavaScript modules will be used to understand the concepts better**

Road Map of the Lecture

- The lecture will visit all the block elements of the control system, first.

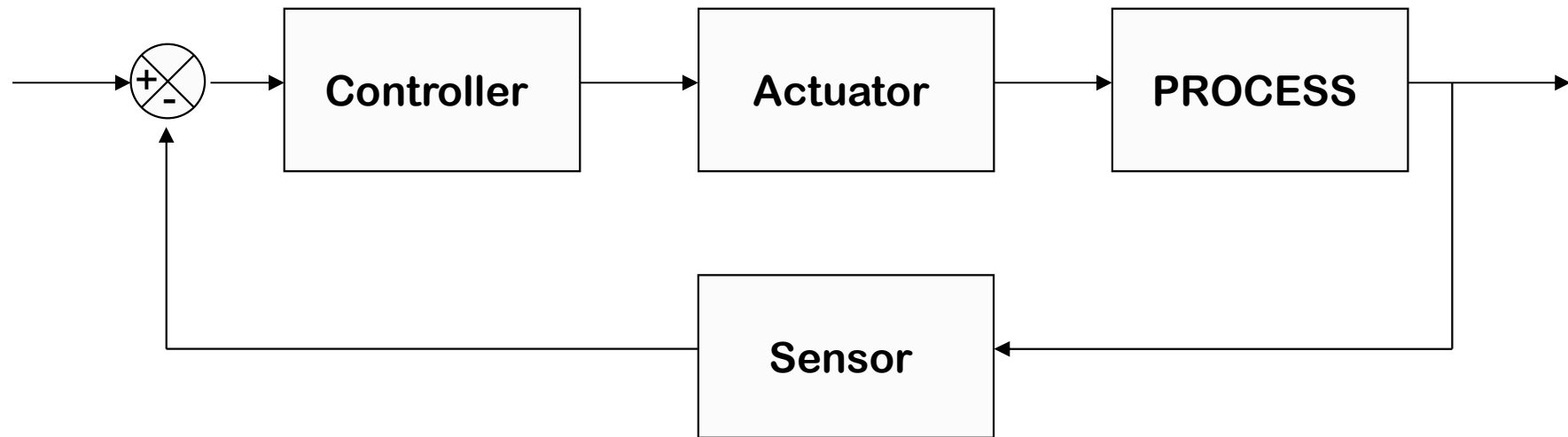

- Then, analyze the whole system all together.
- Then, consider the variations of the elements

**CHBE320 LECTURE I
INTRODUCTION TO PROCESS
CONTROL
AND PID CONTROLLER**

Professor Dae Ryook Yang

Fall 2021

**Dept. of Chemical and Biological Engineering
Korea University**

Road Map of the Lecture I

- **Introduction to Process Control Concepts.**
- **Visit Controller, especially PID controller.**

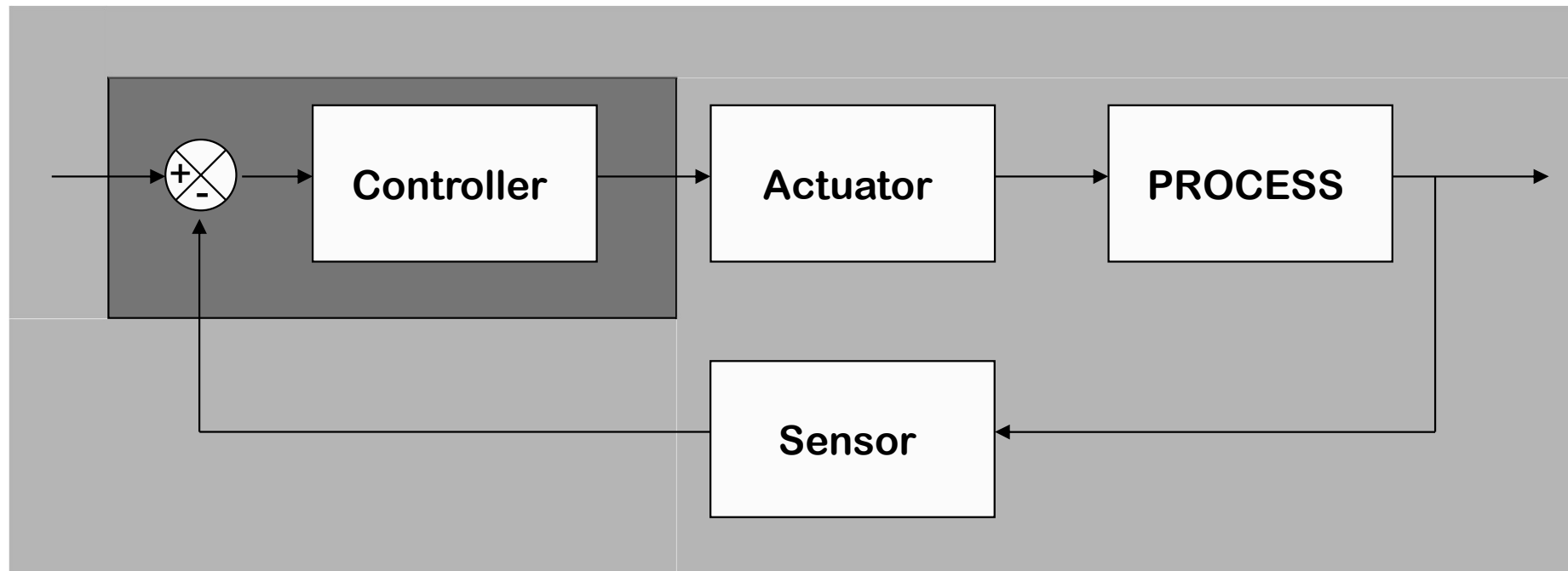

- **Concepts of feedback and feedforward control**
- **Theory of PID controller (advantages and disadvantages)**
- **Variation of PID controller**

INTRODUCTION TO PROCESS CONTROL (1)

- **Goal of Plant Operation**

- Safety
- Production schedule
- Product Quality
- Maximum profit

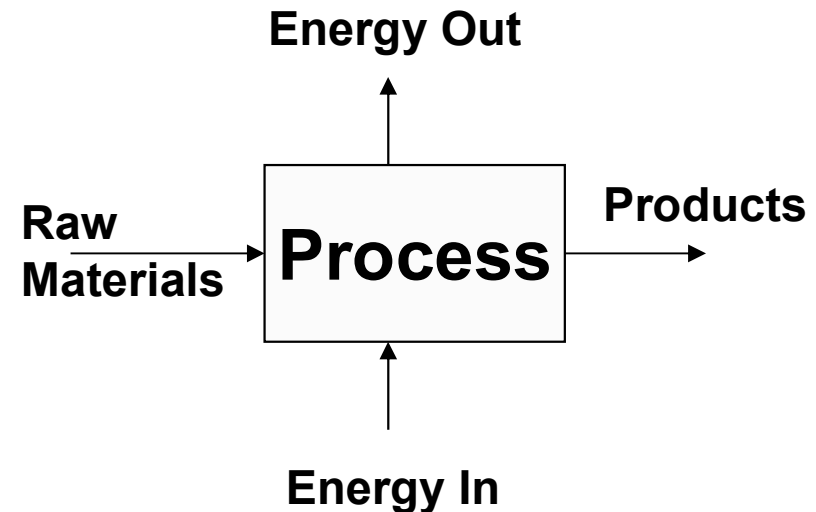

- **Industrial Perspectives**

- Accidents should be avoided (human, properties)
- Exploit the opportunities
- Enterprise image, Loyal customers, Competitiveness
- Game of survival

INTRODUCTION TO PROCESS CONTROL (2)

- **What is Process Control?**

- Monitor the process status
- Drive the process to desired condition
- By manipulating adjustable handles

- **How to Monitor Process Status?**

- Measure important process variables by sensors
- Estimate the important variable through indirect measurements

- **What are Adjustable Handles?**

- Process variables manipulated by actuators
- Ex) flow rate by control valve, motor speed by inverter

Example: Refinery

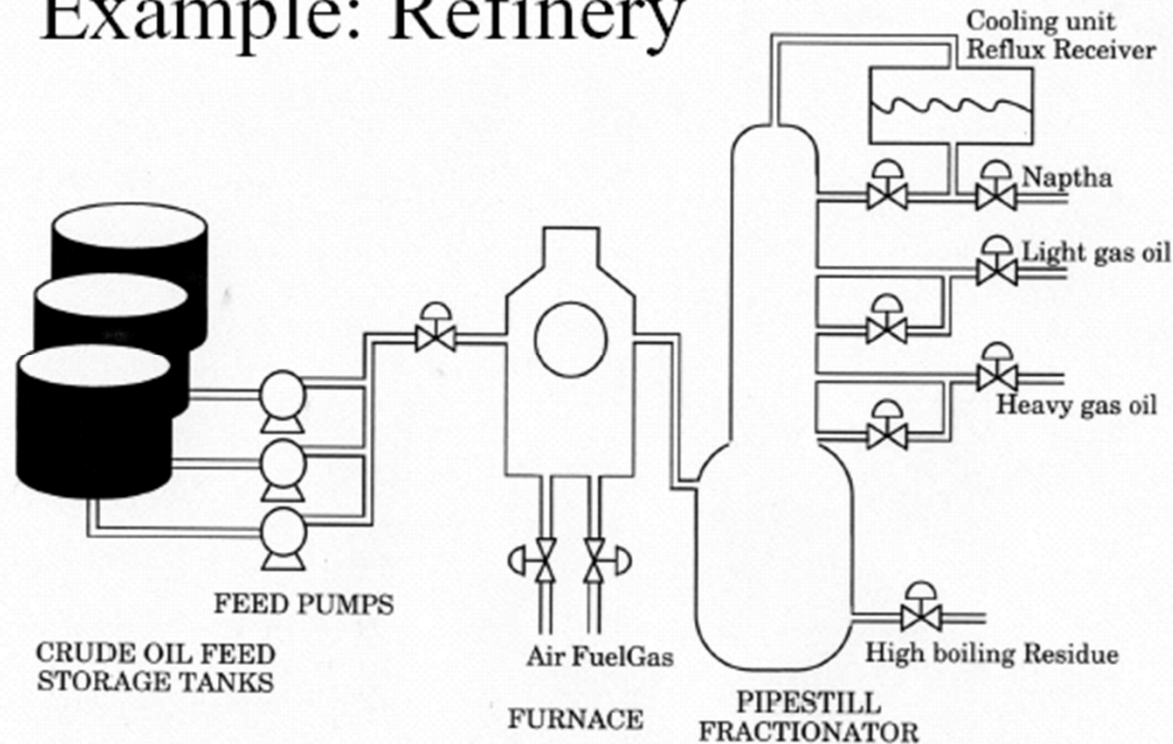

- **Measure product quality (TBP)**
- **Adjust energy input and product distribution**
- **Make more valuable products with least energy**
- **Not to violate any process constraints**

INTRODUCTION TO PROCESS CONTROL (3)

- **Performance of Process Control**
 - Closeness to set points
 - Short transient to one set point to other set points
 - Smaller overshoot and less oscillation
 - Smooth and minimum changes of variable manipulation
 - Minimum usage of raw materials and energy

- **The Needs of Process Control**
 - Stronger competition
 - Tougher environment regulation
 - Tougher safety regulation
 - Rapidly changing economic condition
 - Highly integrated Plants
 - Strict quality control

HOW TO CONTROL A PROCESS

– Assumed Situation

- All important variables to be controlled (CV) are identified and measurable. (CV's are usually direct or indirect quality variables)
- Manipulated variables (MV) to be adjusted will have significant impacts on controlled variable. (MV's are usually affect the CV's)
 - Disturbance variables (DV) cal also affect the CV's but they are not usually manipulatable

– Manual Control

- Read the sensors, then decide the amount of change in adjustable variable, then adjust the variable by changing the knob, or dial and so on.
- See if the controlled variable is moving toward the desired set point (SP) fast enough
- Repeat this procedure perpetually unless you are 100% sure that the process will not deviate from set points

Example: Crude Oil Furnace

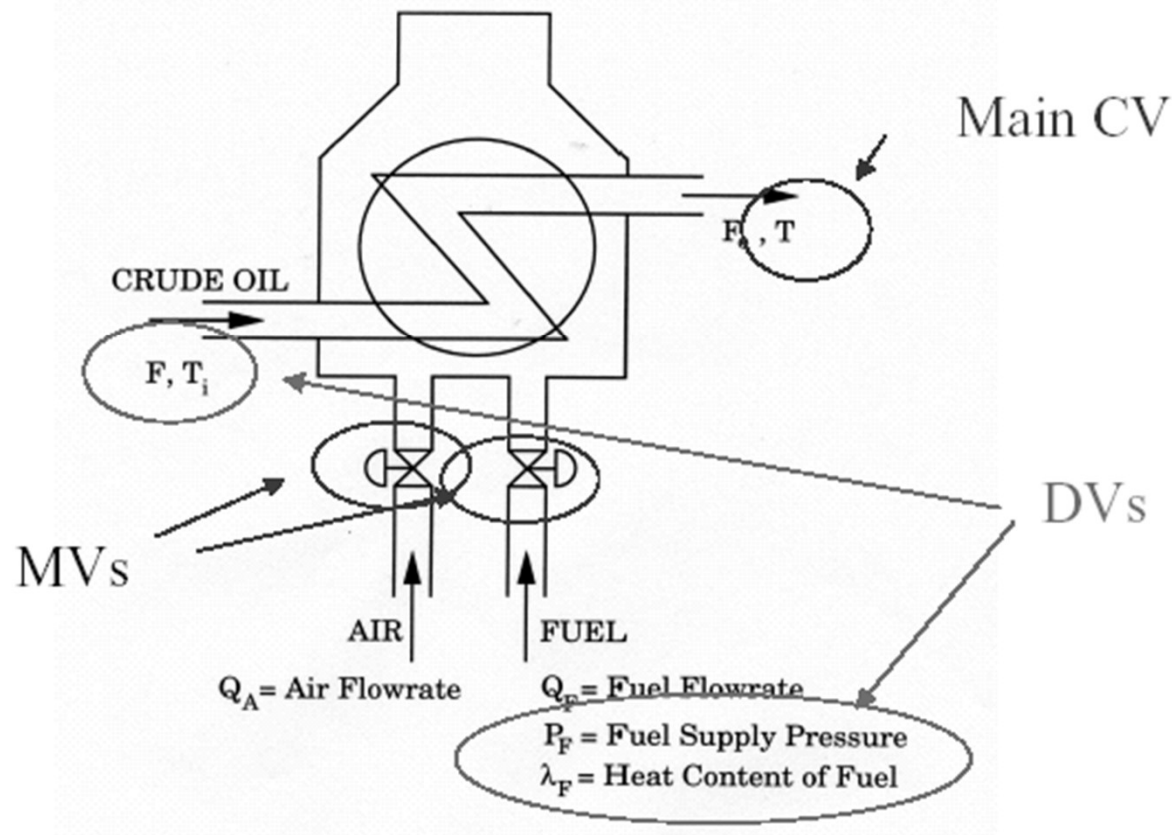

- Operator have to change two MV's for one CV
- Operator relies on the observations and prior experiences
- Corrected by Trial and error, Inconsistent, Unreliable

FEEDBACK CONTROL

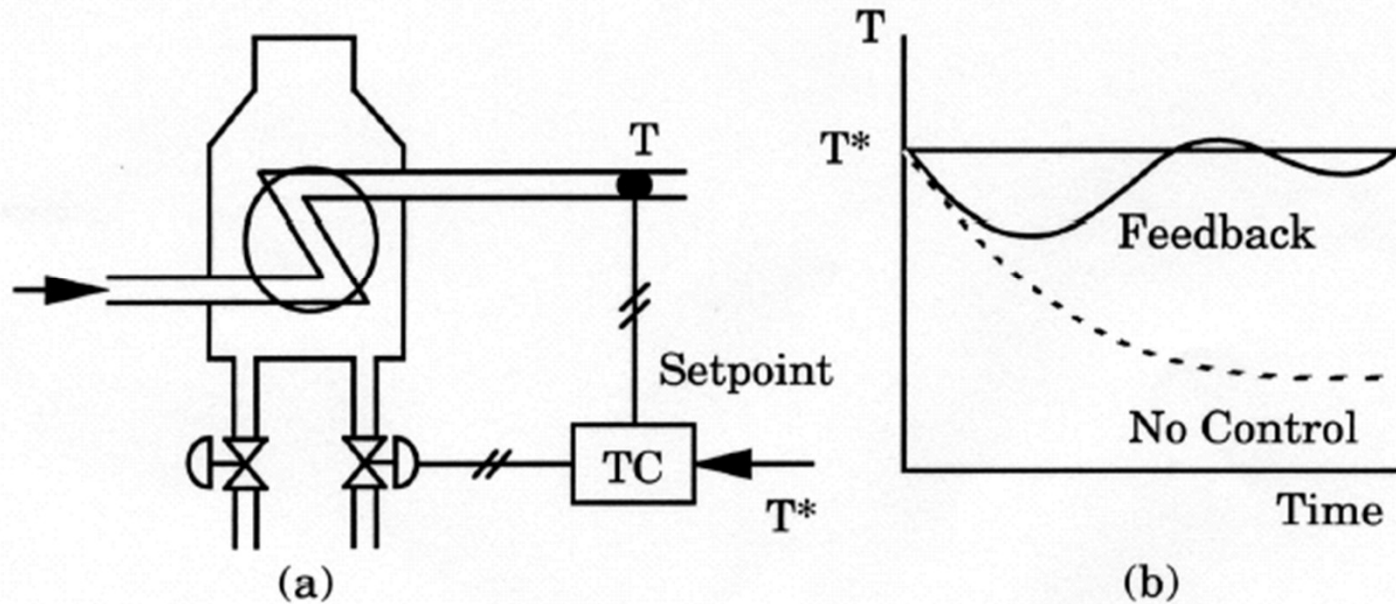

- **Controller will adjust the fuel valve somehow until T is settled at set point**
- **The fuel valve will be adjusted only after some change happen at the measurement**

FEEDFORWARD CONTROL

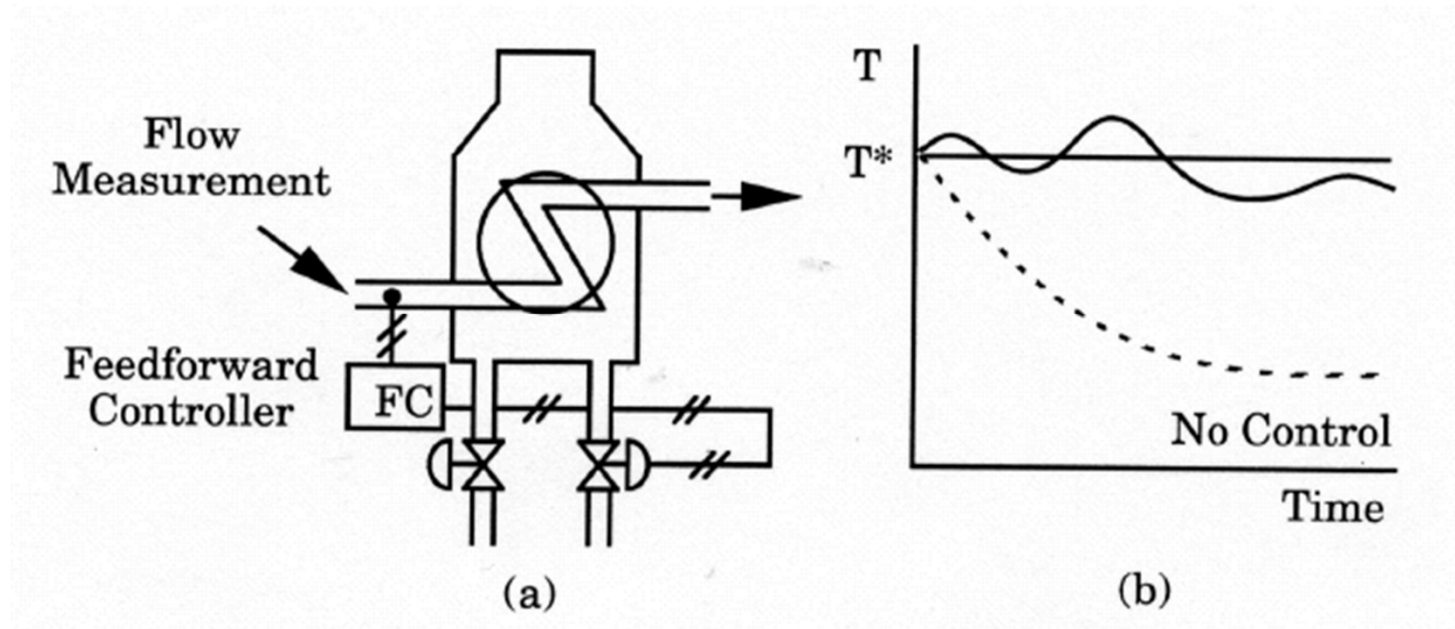

- If there is a change in feed flow, controller will change fuel flow and exit temperature will not deviate too much
- But the correction is based on the estimated effect of feed flow rate on T and if it is not accurate, the exit T will not be at set point

COMBINED FF/FB CONTROL

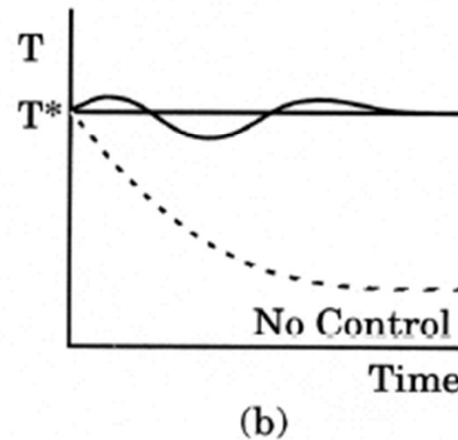
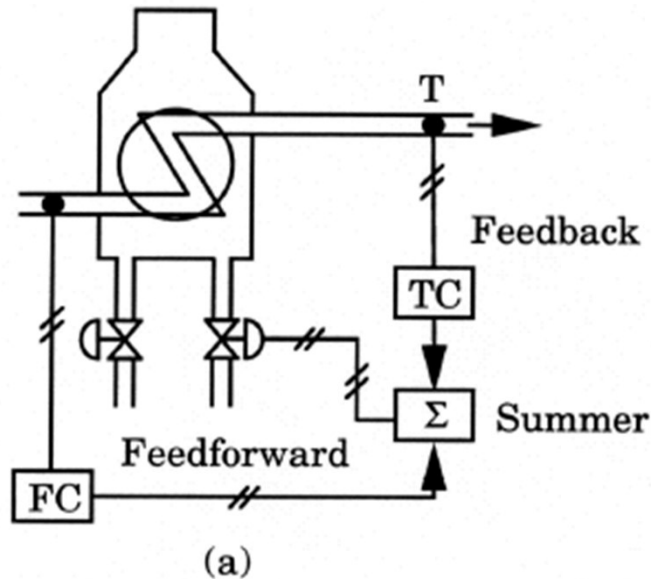

- Obtain combined advantages of FF and FB control
- But if there is a change in fuel pressure, this strategy will act only after the effect appears at exit temperature

FF/FB + CASCADE CONTROL

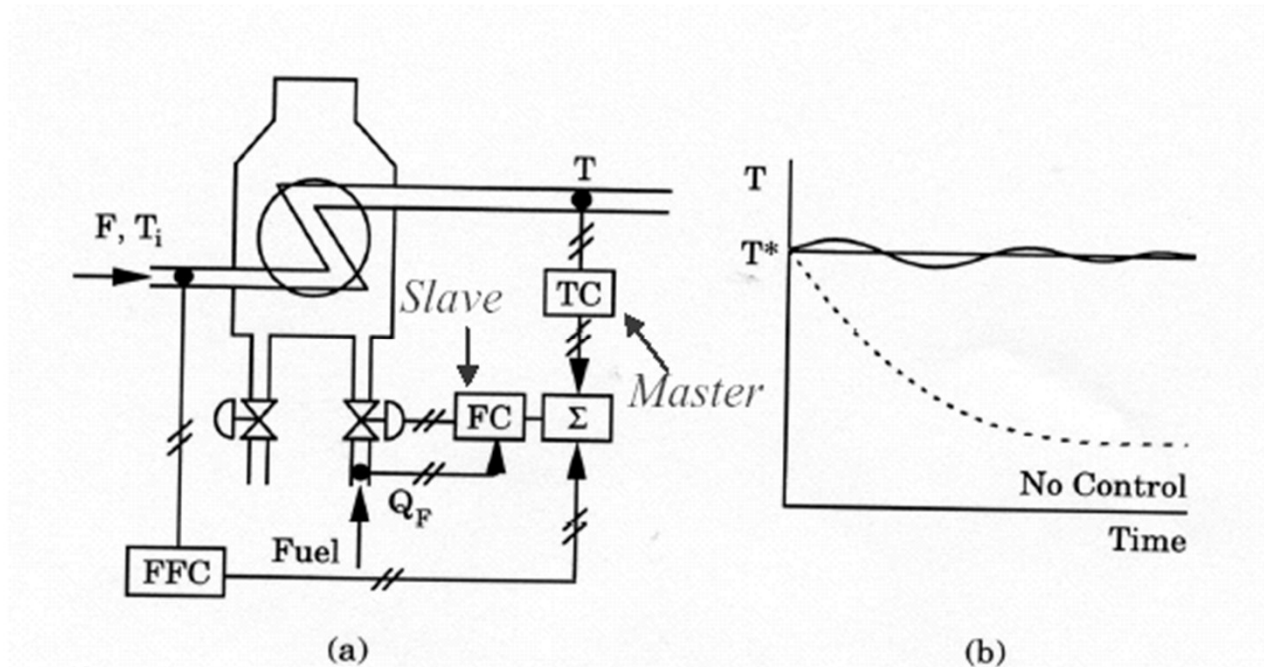

- **Better than the others (Best so far)**
- **There can be other requirements to enhance the control performance**
- **Need to design controllers based on the objectives given**

CLASSIFICATION OF CONTROL

- **Based on the decision**
 - **Feedback Control: based on measurement of CV**
 - **Feedforward Control: based on measurement of DV**
 - **Open-loop Control: based on predetermined scenario**

- **Based on set point type**
 - **Regulatory control: follow constant set point overcoming the disturbance**
 - **Servo control: follow the changing set point**

CLASSIFICATION OF VARIABLES

- **Input**
 - **MV (Manipulated Var.): Operator can adjust (Fuel flow rate)**
 - **DV (Disturbance Var.): Decided by external reasons (Feed flow, Fuel Press.) (measured DV and unmeasured DV)**
 - **Fixed inputs**
- **Output**
 - **CV (Controlled Var.): Decided by the changes in input variables (assumed to be measured)**
 - **Measured and unmeasured outputs**
- **State**
 - **Variables determining internal dynamic condition including outputs**

JUSTIFICATION OF PROCESS CONTROL

- **Due to the uncertainties**
 - Imperfect process design
 - Disturbances and Changes in operating condition
 - Difficulties in startup and shutdown
- **Through control, we can achieve**
 - Safe operation
 - Satisfying environmental constraints
 - Economic benefit
 - Increased production level
 - Reduced raw material cost
 - Enhanced product quality
 - Extended equipment life
 - Potential benefits of improved process control

ELEMENTS OF PROCESS CONTROL LOOP

- Process
- Sensor
- Transmitter
- Controller
- Actuator

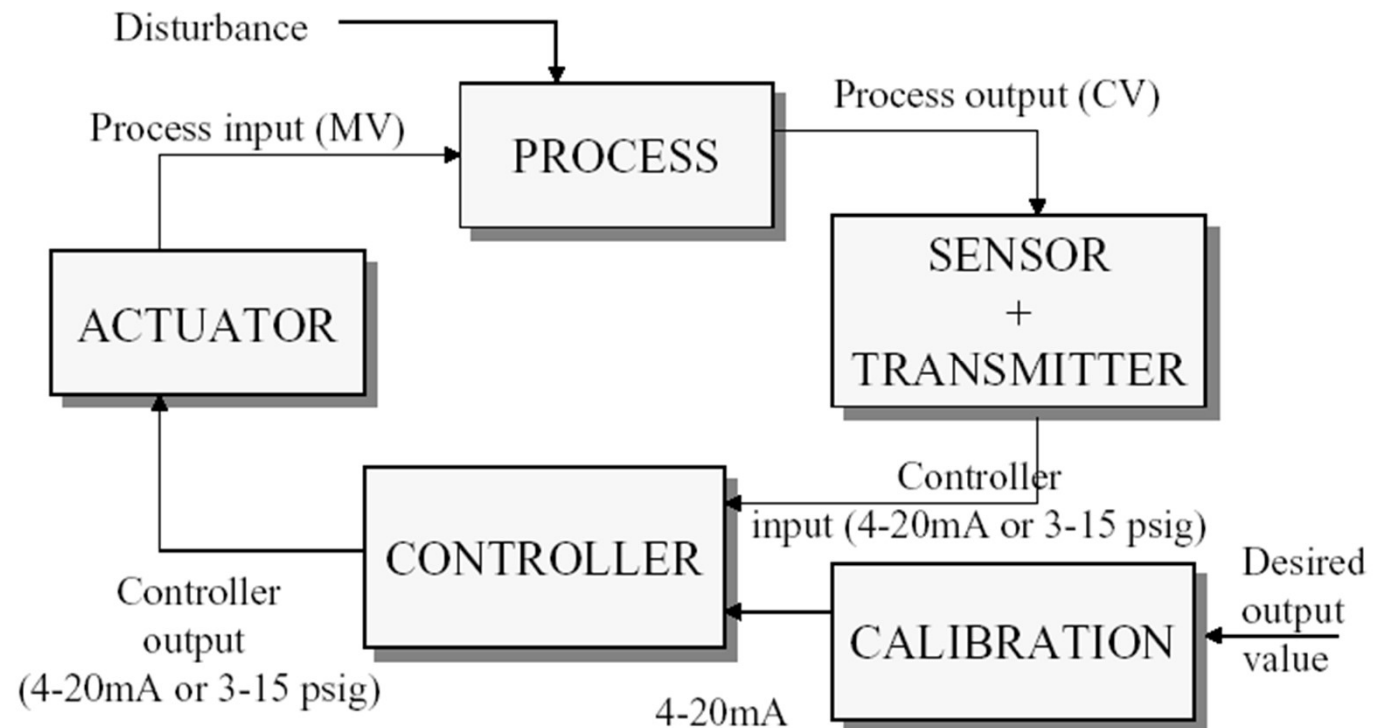

PID CONTROLLER

- **Input and Output of a Controller**

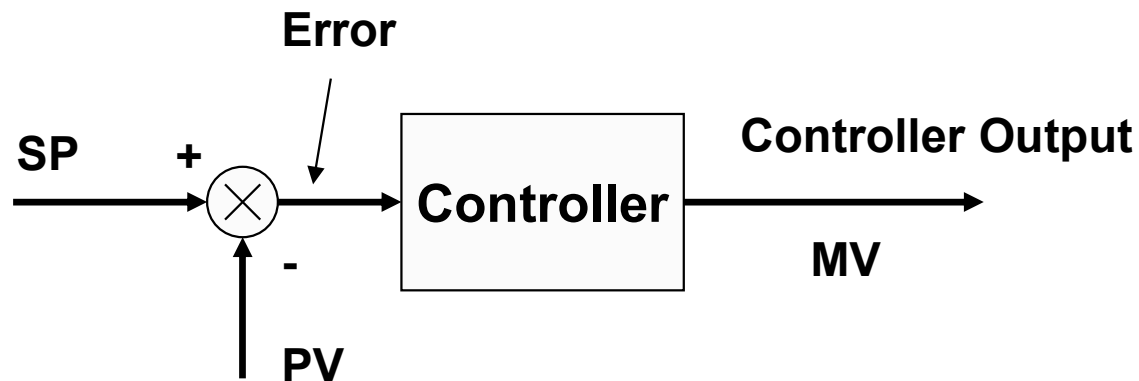

- **Controller decides “what to do” based on the error between the desired value (SP) and process measurement (PV)**
- **Intuitively, if the error is large, make large change in MV and if the error is small, make small change in MV**
 - $\Rightarrow (MV) \propto K_c \cdot (\text{Error})$
- **The sign of K_c has to be determined to the direction of reducing error**

P CONTROL

- **Proportional Control**

$$p(t) = \bar{p} + K_c e(t)$$

↑ ↑ ↑
Controller output Nominal value, bias Proportional Gain

- **Error = (SP) – (Measured PV) $e(t) = R(t) - B(t)$**
- **When the PV gets larger, controller should increase the $p(t)$ in order to reduce the error, then choose negative K_c value**
 - ⇒ **Direct acting mode (e.g., coolant control)**
- **When the PV gets smaller, controller should increase the $p(t)$, then choose positive K_c value**
 - ⇒ **Reverse acting mode (e.g., flow control)**

- **Proportional band (PB)**

$$PB = 100/K_C \quad [\%]$$

- PB means the size of error change which causes a full span change in actuator by the controller.
- For example, for $K_c=2$, PB=50%. For the error change from -25% to $+25\%$ (net change=50%), $p(t)$ will change from 0% to 100% when the bias is 50%.
- **As error changes, $p(t)$ will change immediately**
 - \Rightarrow fast corrective action and it is in very simple form.
- **If PV reaches SP, error becomes zero. Then $p(t) = \bar{p}$**
But if there is a change in DV or SP, $p(t)$ should be different and error cannot be zero.
 - \Rightarrow inevitably results some discrepancy between SP and PV which is called “offset”
 - For nonzero $p(t) - \bar{p}$, $e(t)$ can be very small when K_c is very large

PI CONTROL

- To eliminate the offset, \bar{p} should be adjusted and reach a constant value when error becomes zero.

$$p(t) = \bar{p} + C \int_0^t e(t^*) dt^* \quad (\text{I-Control})$$

- The integral mode will change the bias value until the error becomes zero \Rightarrow Eliminate offset
 - The action is not immediate until the integral becomes significant. Also, the integral mode tends the system to be more oscillatory, even unstable
- **Proportional-Integral Control**

$$p(t) = \bar{p} + K_c \left(e(t) + \frac{1}{\tau_I} \int_0^t e(t^*) dt^* \right)$$

Integral time or reset time

- **Advantages (Combined benefits)**
 - Fast action
 - Eliminate the offset
- **Disadvantage**
 - Oscillatory or unstable with integral control
 - One more parameter to tune
- **Reset rate:** $\tau_R = 1/\tau_I$
 - Infinite integral time or zero reset rate \Rightarrow P control

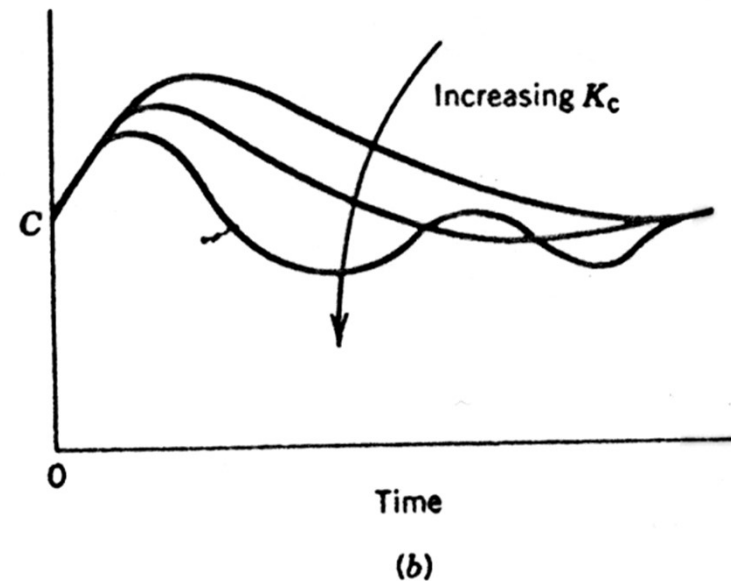
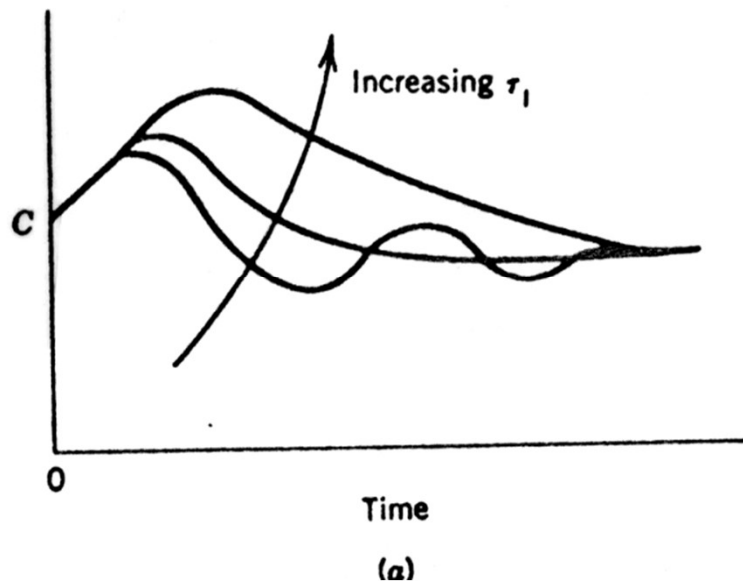

- **Reset Time**

- If, for some reason, the error is maintained at some value despite the control, the integral mode will reset the bias value continuously.

$$p(t) = \left(\bar{p} + \frac{K_c}{\tau_I} \int_0^t e(t^*) dt^* \right) + K_c e(t)$$

new \bar{p} ↓ Constant, e ↓

$$p(t) = \left(\bar{p} + \frac{t}{\tau_I} K_c e \right) + K_c e$$

- The bias value will be reset every τ_I by the amount of action taken by the P control. \Rightarrow called “reset time”

- **Reset windup or Integral windup**

- Even though the calculation of the control action is limited to 0-100% and clipped, the calculation can be any value.
- If it takes long time to reach steady state (e.g., start-up), the error will be accumulated in the integral term.

- The accumulated value in the integral term can be well over the limit when PV reaches SP. Once the PV passes SP, the MV should be decreased not to pass the SP further.
- However, the integral term can be much greater (smaller) than 100% (0%), and in this the action by P term cannot affect the I term and the decrease in I term will not be immediate. The controller output will still be at the limit for a while.
- Then the PV will exceed SP further and it take long time for the controller output to reach inside the limit.
- Similar phenomenon happens when it goes the other way.
⇒ causes “large oscillation”
- **Remedy: Anti-reset windup**
 - Stop the integration when the output saturates
 - Use reset feedback (actual output) instead of calculated output
 - Use velocity form
$$\frac{dp}{dt} = K_c \left(\frac{de}{dt} + \frac{1}{\tau_I} e(t) \right)$$

USE OF RESET FEEDBACK

- **Compensate the integration when the calculated controller output and actual controller output are different due to the output range**

$$p(t) = \bar{p} + \frac{1}{\tau_{aw}} \int_0^t [vp(t^*) - p(t^*)] dt^* + K_c \left(e(t) + \frac{1}{\tau_I} \int_0^t e(t^*) dt^* + \tau_D \frac{de}{dt} \right)$$

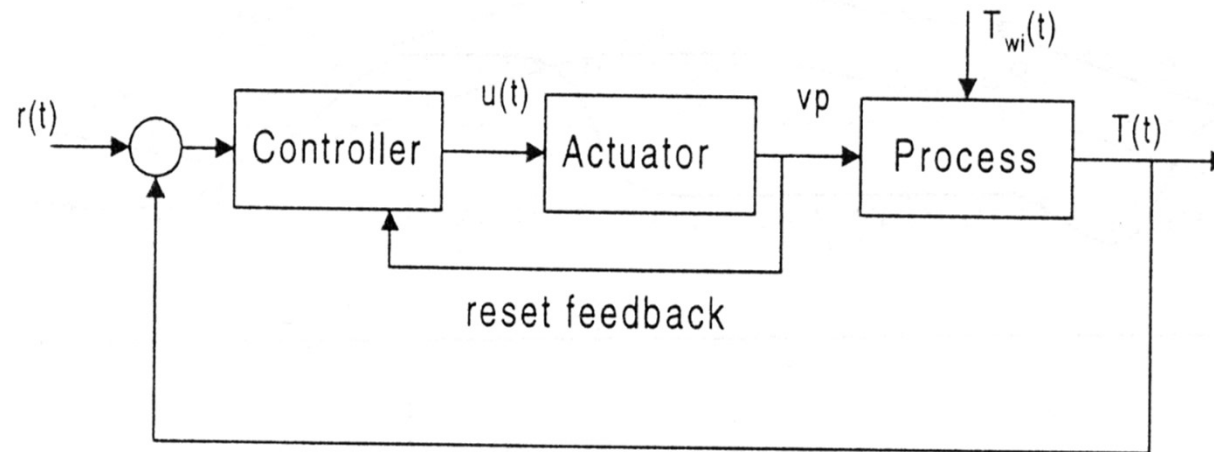

PID CONTROL

- **The process usually have some capacity**
 - It takes time for the effect of input change to appear in the output (lag or time constant)
 - If the error change (not the error itself) is decreasing (increasing), the input to the process should be adjusted accordingly.

- **Adding D control mode** Derivative time or Preact time

$$p(t) = \bar{p} + k_c \left(e(t) + \frac{1}{\tau_I} \int_0^t e(t^*) dt^* + \tau_D \frac{de(t)}{dt} \right)$$

- D mode will anticipate the change of error and make the process output to land on set point smoothly. (less settling time)
- D mode tends to reduce the oscillation and enhance the stability and the action is immediate.
- If there is noise in the PV, noise will be amplified by the derivative.

- The derivative requires information on error in the future : impossible \Rightarrow uses approximation of derivative
- Another parameter to tune: quite complicated for three tuning parameters
- If the measurement is noisy, use the measurement after smoothing out (filtering)
- **Derivative Kick**
 - If there is a sudden change in SP (step change), the derivative of error will be extremely large momentarily.
 - The control action goes to the limit and returns when ever SP changes suddenly. \Rightarrow called “derivative kick”
 - To avoid derivative kick
 - Make a gradual change in SP
 - Use modified PID form

$$\frac{de(t)}{dt} = \frac{d(R(t) - B(t))}{dt} \approx -\frac{dB(t)}{dt}$$

Exact except when $R(t)$ changes

- **Proportional Kick**

- In P mode, if there is a sudden change in SP, the P term changes abruptly \Rightarrow it may or may not be desirable

- Use modified form:

$$p(t) = \bar{p} + K_c(\alpha r(t) - y(t)), \quad 0 \leq \alpha \leq 1$$

- When α is 1, it is the ordinary form of P control
- When α is 0, proportional kick is eliminated

- If α is 0, SP is vanished in the controller calculation, it may cause drift if I mode is not used together.

- **Preact time**

- If, for some reason, the error is increased at some rate (a) despite the control, the integral mode will reset the bias value continuously

$$p(t) = \bar{p} + K_c \tau_D \frac{de(t)}{dt} + \underbrace{K_c e(t)}_{\text{Constant}}$$

$$p(t) = \bar{p} + K_c a(\tau_D + t) \quad \leftarrow \text{Act ahead by } \tau_D$$

BUMPLESS TRANSFER

- When the controller is switched to “AUTO” from “MAN”, the initial controller output will be \bar{p} which may not be same as current MV.
- Then the process input changes from the MV in manual mode to \bar{p} . \Rightarrow causes bump initially
- To avoid this, set the initial controller output as MV value before switching.

$$p(t) = \bar{p} + \left(\frac{K_c}{\tau_I} \int_0^t e(t^*) dt^* + K_c e(t) - K_c \tau_D \frac{dB_F}{dt} \right)$$

Set this value as MV value before switching

Filtered measurement