

Dynamic Simulation for T-9 Storage Tank (Holding Case)

CASE 1: 19,642 Kg/Hr (Holding: 52°C), No Liquid Draw

Workshop Description

- Estimation of vapor flow rate coming out from the T-9 tank for holding case (52°C) using dynamic simulation.
- Schematic diagram for T-9 tank holding case is shown below in Figure 1.

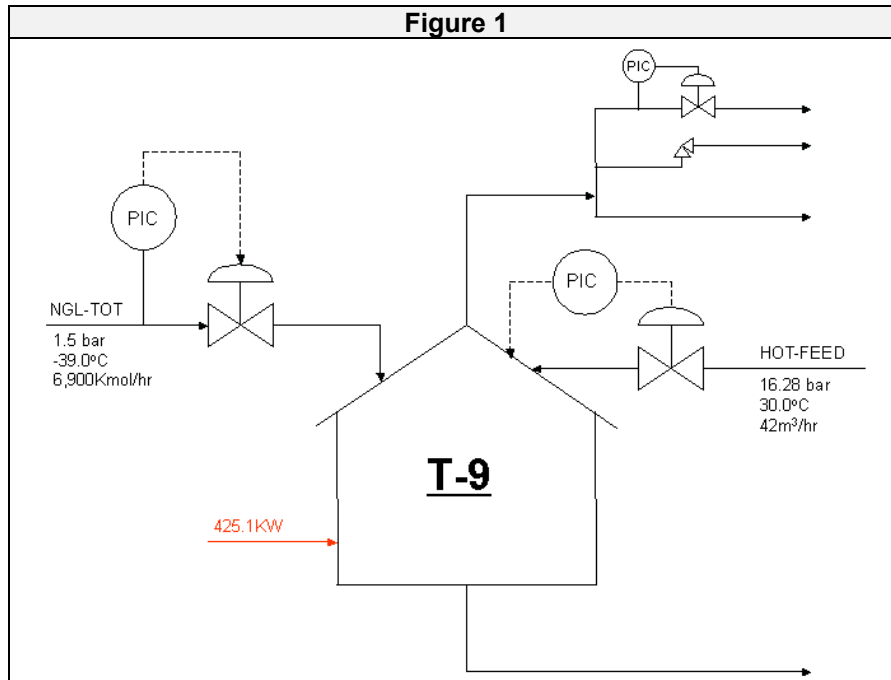

- Feed conditions and compositions for stream NGL-TOT & HOT-FEED are shown in Table 1.

Table 1		
Stream	NGL-TOT	HOT-FEED
Temperature (°C)	-39.0	42.0
Pressure (bar)	1.50	2.5
Component		
Ethane	0.020	0.020
Propane	0.976	0.976
Iso-butane	0.003	0.003
N-butane	0.001	0.001
Flowrate	6,900 Kmole/hr	42m ³ /hr

Building a Steady State Simulation for T-9 tank.

- Open the Component List View.

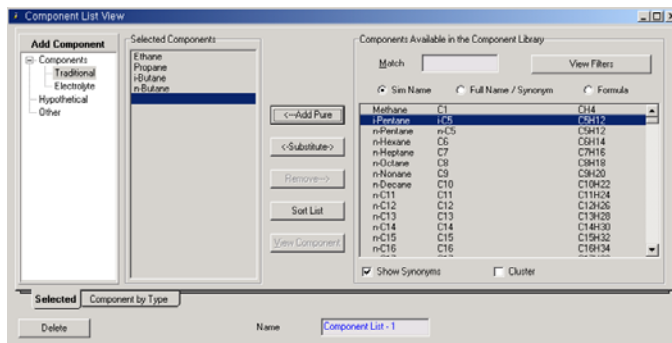

- Open the Fluid Package View.

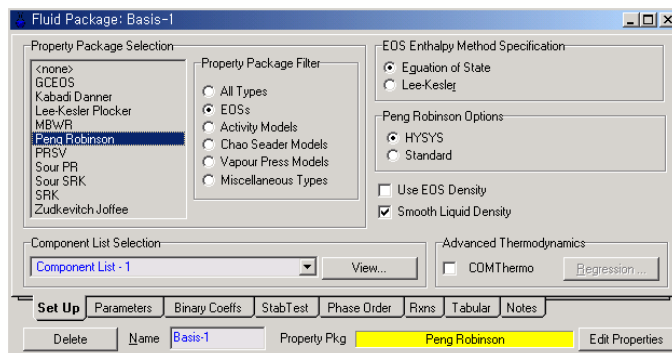

- Selecting a Unit Set.

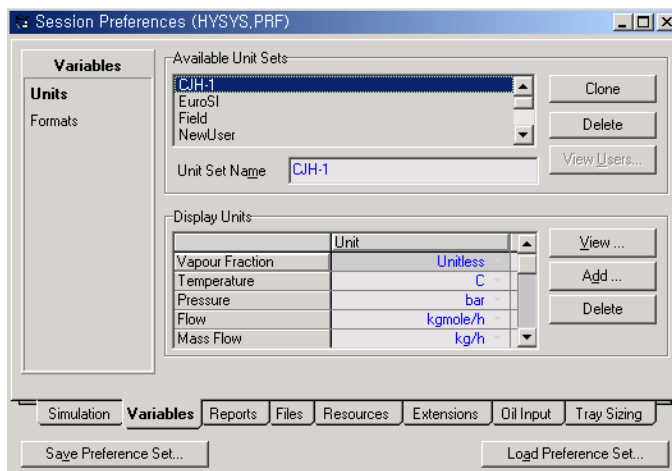

- Adding Streams

In HYSYS, there are two types of streams, Material and Energy. Material streams have a composition and parameters such as temperature, pressure and flow rate. They are used to represent Process Streams. Energy streams have only one parameter, Heat Flow. They represent heating and cooling duties in a plant as well as power to drive pumps and compressors.

Entering Stream conditions and compositions for streams TOT-NGL & HOT-FEED.

TOT-NGL

Stream Name	TOT-NGL
Vapour / Phase Fraction	<empty>
Temperature [C]	-39.000
Pressure [bar]	1.5000
Molar Flow [kgmole/h]	6900.0
Mass Flow [kg/h]	<empty>
Std Ideal Liq Vol Flow [m3/h]	<empty>
Molar Enthalpy [Btu/lbmole]	<empty>
Molar Entropy [UserUnit*]	<empty>
Heat Flow [kcal/h]	<empty>
Liq Vol Flow @Std Cond [barrel/day]	<empty>
Fluid Package	Basis-1

Worksheet Attachments Dynamics

Unknown Compositions

Delete Define from Other Stream... ← →

TOT-NGL

	Mole Fractions
Ethane	0.020000
Propane	0.976000
i-Butane	0.003000
n-Butane	0.001000

Total 1.00000

Edit... Edit Properties... Basis...

Worksheet Attachments Dynamics

OK

Delete Define from Other Stream... ← →

HOT-FEED

Stream Name	HOT-FEED
Vapour / Phase Fraction	1.00000
Temperature [C]	30.000
Pressure [bar]	2.5000
Molar Flow [kgmole/h]	482.52
Mass Flow [kg/h]	21169
Std Ideal Liq Vol Flow [m3/h]	42.000
Molar Enthalpy [Btu/lbmole]	-4.451e+004
Molar Entropy [UserUnit*]	156.73
Heat Flow [kcal/h]	-1.1939e+07
Liq Vol Flow @Std Cond [barrel/day]	6313.3
Fluid Package	Basis-1

Worksheet Attachments Dynamics

OK

Delete Define from Other Stream... ← →

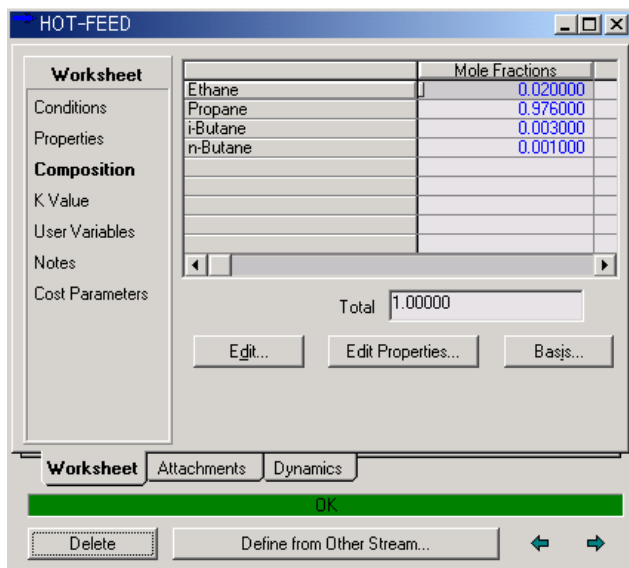

- For VLV-100 (Connection Tab)

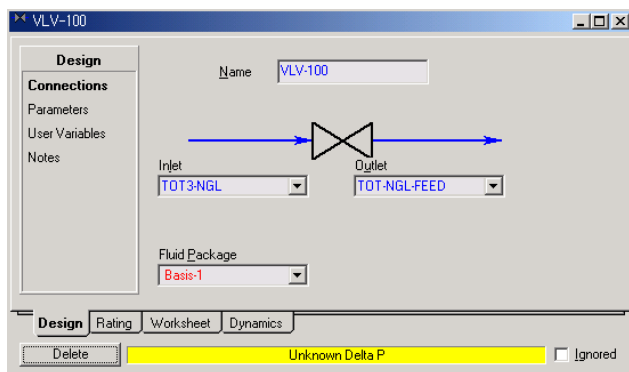

- For VLV-100 (Parameters Tab)

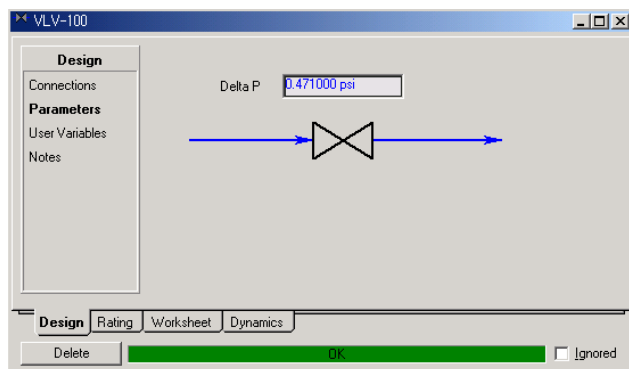

- For VLV-101 (Connection Tab)

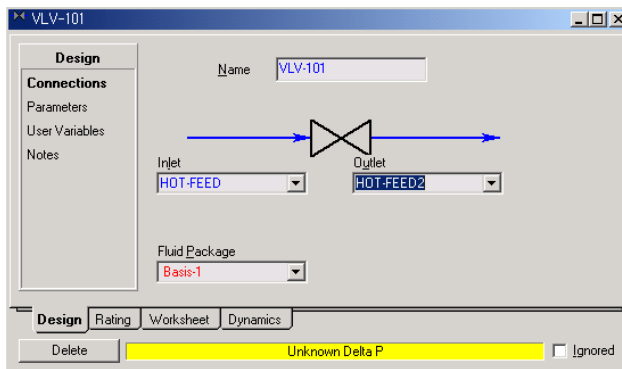

- For VLV-101 (Parameters Tab)

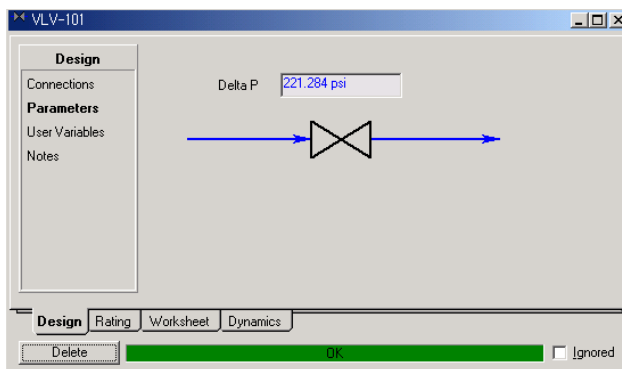

- For VLV-102 (Connection Tab)

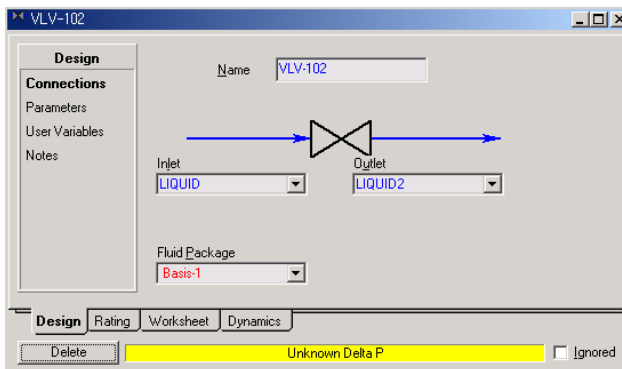

- For VLV-103 (Connection Tab)

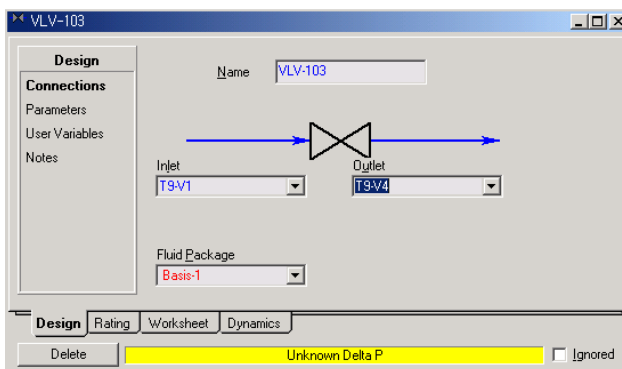

- For VLV-103 (Parameters Tab)

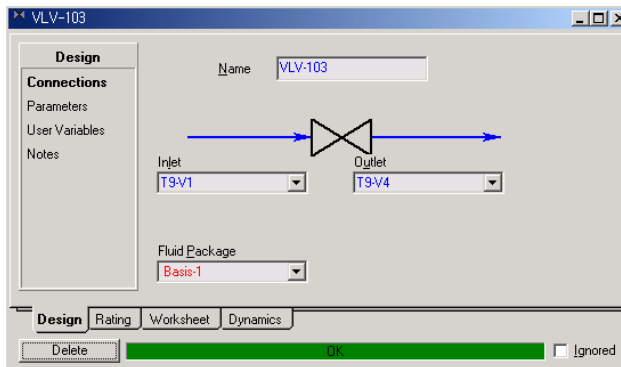

- For VLV-104 (Connection Tab)

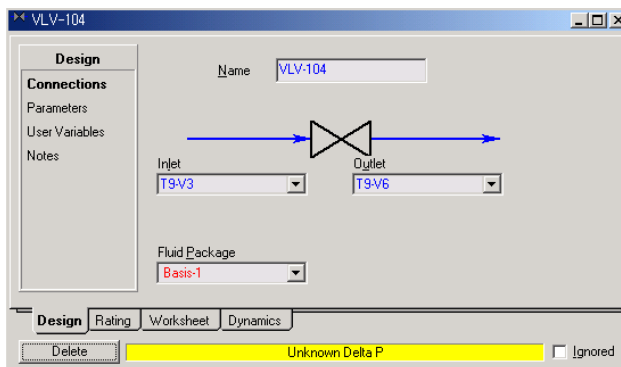

- For VLV-103 (Parameters Tab)

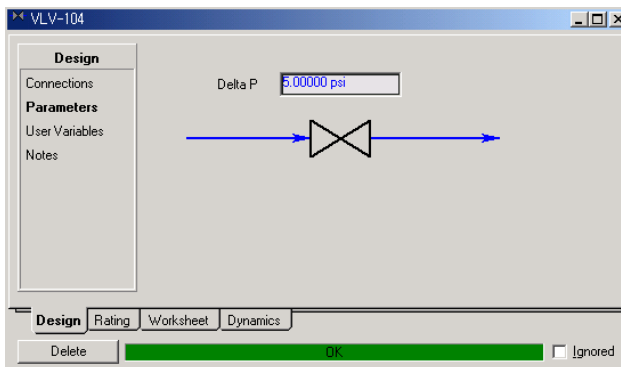

- For RV-100 (Connection Tab)

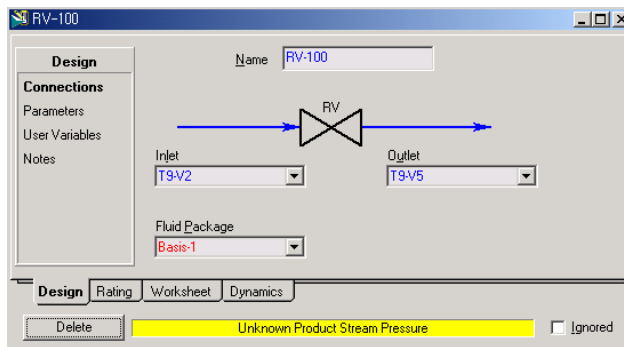

- For RV-100 (Parameters Tab)

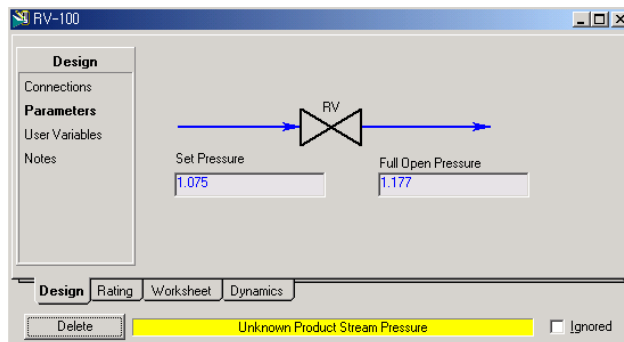

- For T-9 (Connection Tab)

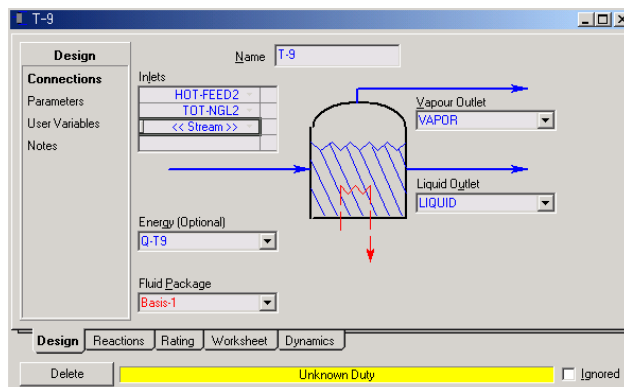

- For T-9 (Parameters Tab)

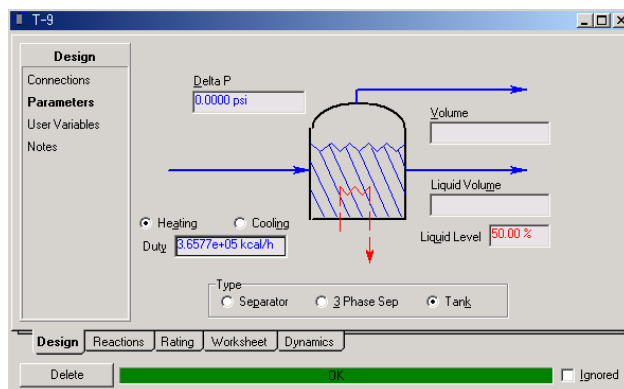

- For T-9 (Parameters Tab)

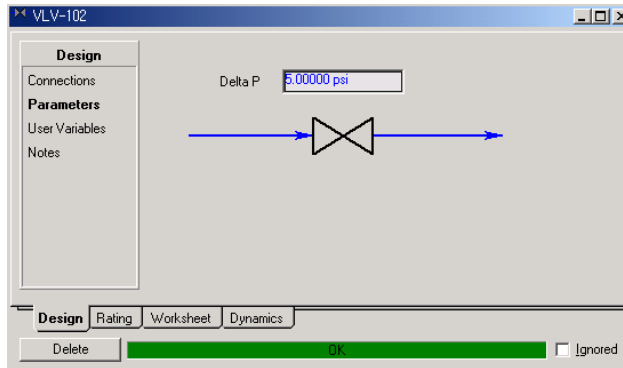

- Save your case as T9-Holding-52C-Steady.hsc.

- Flowsheet Configuration (1)

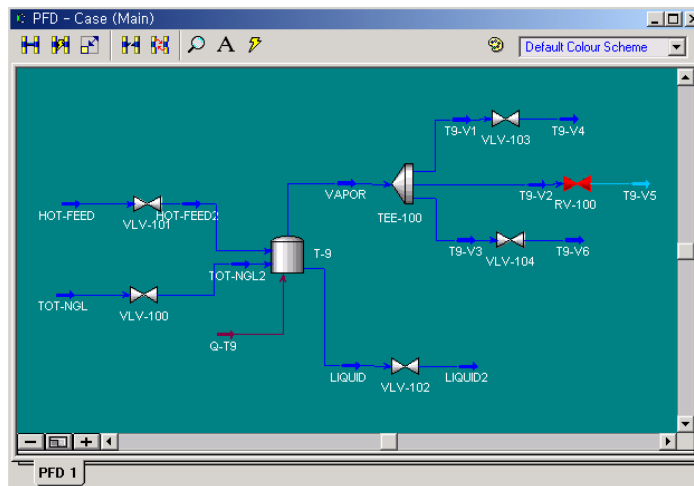

Transitioning from Steady State to Dynamics

All unit operations in the simulation need to be sized using actual plant equipment or predetermined sizing techniques. Vessels should be sized to accommodate actual plant flow rates and pressures while maintaining acceptable residence times.

- Sizing the Valves
 - Valve type (linear, quick opening or equal percentage)
 - The normal valve opening position
 - The pressure drop across the valve
 - The current flow rate

VLV-100

Rating

Sizing (dynamics)

Sizing Conditions

Inlet Pressure [bar]	1.500
Molecular Weight	43.87
Valve Opening [%]	50.00
Delta P [psi]	0.4710
Flow Rate [kg/h]	3.027e+005

Current
 User Input

Valve Type and Sizing Method

Linear
 Quick Opening
 Equal Percentage

Method: Cv Cg k

Cv	25.0
Km	3.585e-002
Cv [USGPM]	5118
Cg	1.2795e+00

Size Valve

Design **Rating** Worksheet Dynamics

Delete **OK** Ignored

VLV-101

Rating

Sizing (dynamics)

Sizing Conditions

Inlet Pressure [bar]	16.28
Molecular Weight	43.87
Valve Opening [%]	50.00
Delta P [psi]	221.3
Flow Rate [kg/h]	2.117e+004

Current
 User Input

Valve Type and Sizing Method

Linear
 Quick Opening
 Equal Percentage

Method: Cv Cg k

Cv	25.0
Km	3.585e-002
Cv [USGPM]	42.65
Cg	1066.3

Size Valve

Design **Rating** Worksheet Dynamics

Delete **OK** Ignored

VLV-102

Rating

Sizing (dynamics)

Sizing Conditions

Inlet Pressure [bar]	1.468
Molecular Weight	43.90
Valve Opening [%]	50.00
Delta P [psi]	5.000
Flow Rate [kg/h]	3.156e+005

Current
 User Input

Valve Type and Sizing Method

Linear
 Quick Opening
 Equal Percentage

Method: Cv Cg k

Cv	25.0
Km	3.585e-002
Cv [USGPM]	1762
Cg	44060

Size Valve

Design **Rating** Worksheet Dynamics

Delete **OK** Ignored

VLV-103

Rating

Sizing (dynamics)

Sizing Conditions

Inlet Pressure [bar]	1.468
Molecular Weight	42.73
Valve Opening [%]	50.00
Delta P [psi]	0.4351
Flow Rate [kg/h]	2481

Current
 User Input

Valve Type and Sizing Method

Linear
 Quick Opening
 Equal Percentage

Method: Cv Cg k

Cv	25.0
Km	3.585e-002
Cv [USGPM]	556.4
Cg	13910

Size Valve

Design **Rating** Worksheet Dynamics

Delete **OK** Ignored

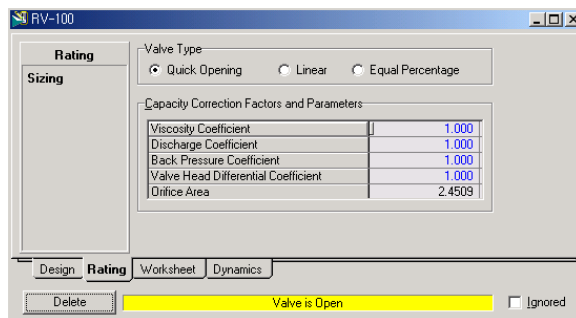
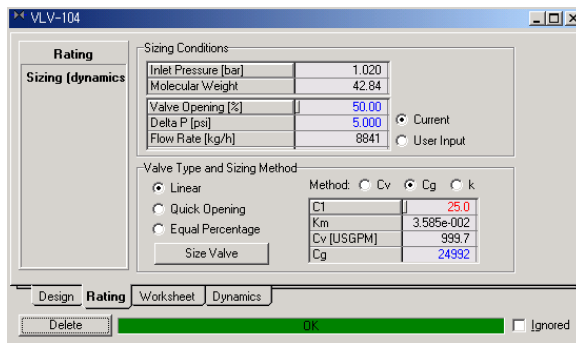

Note that the normal valve opening percent of VLV-102 should be 0.0 percent instead of 50.0 percent for a holding case.

- Sizing the Separator
 - Open the dynamic tab of the separator.
 - Enter 182.1 ft for a vessel diameter and 78.74 ft for vessel height.

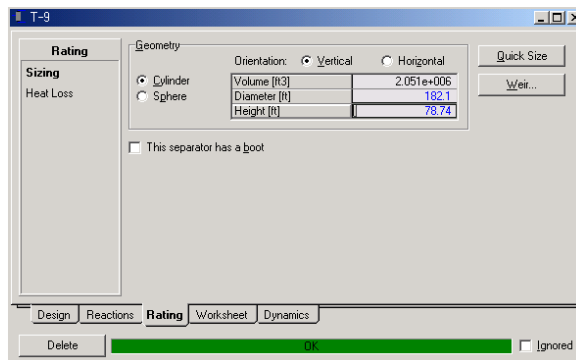

- Save your case as T9-Holding-52C-Sizing.hsc.

Making Pressure-Flow and Dynamics Specifications

- Analysis of the Process Flowsheet
 - For the current simulation, the boundary streams are TOT-NGL, HOT-FEED, LIQUID2, T9-V3, and T9-V4. All boundary streams in the Flowsheet must have a pressure specification.
 - On the Dynamics tab of the TOT-NGL, HOT-FEED, LIQUID2, T9-V4, T9-V5 and T9-V6, select the Pressure Specification by checking the box Active.

TOT-NGL

Dynamics

Specs
Stripchart

Dynamic Specifications

Pressure Specification

Pressure	Active
1.500 bar	<input checked="" type="checkbox"/>

Flow Specification

Molar
 Mass
 Ideal LiqVol
 Std. LiqVol

Molar Flow	Active
6900 kgmole/h	<input type="checkbox"/>

Feeder block...

Worksheet Attachments **Dynamics**

OK

Delete Define from Other Stream... ← →

HOT-FEED

Dynamics

Specs
Stripchart

Dynamic Specifications

Pressure Specification

Pressure	Active
16.28 bar	<input checked="" type="checkbox"/>

Flow Specification

Molar
 Mass
 Ideal LiqVol
 Std. LiqVol

Ideal Liquid Volume Flow	Active
42.00 m3/h	<input type="checkbox"/>

Feeder block...

Worksheet Attachments **Dynamics**

OK

Delete Define from Other Stream... ← →

LIQUID2

Dynamics

Specs
Stripchart

Dynamic Specifications

Pressure Specification

Pressure	Active
1.123 bar	<input checked="" type="checkbox"/>

Flow Specification

Molar
 Mass
 Ideal LiqVol
 Std. LiqVol

Molar Flow	Active
7189 kgmole/h	<input type="checkbox"/>

Product block...

Worksheet Attachments **Dynamics**

OK

Delete Define from Other Stream... ← →

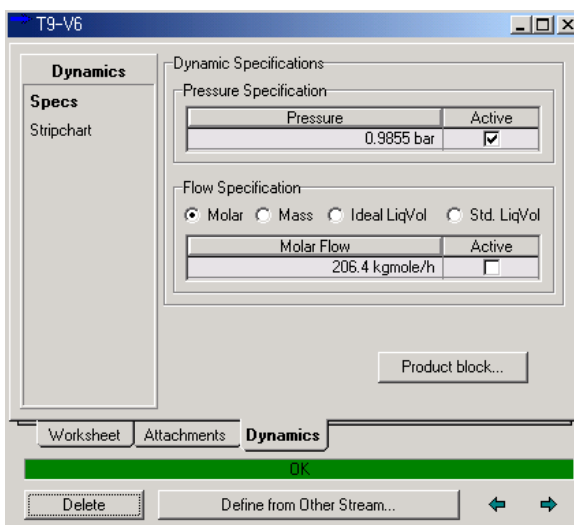
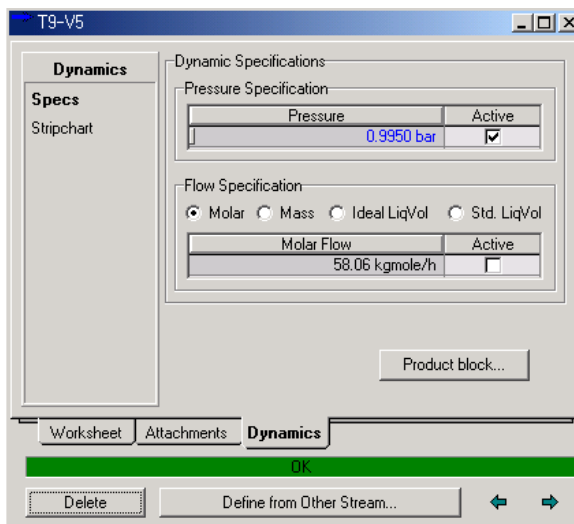
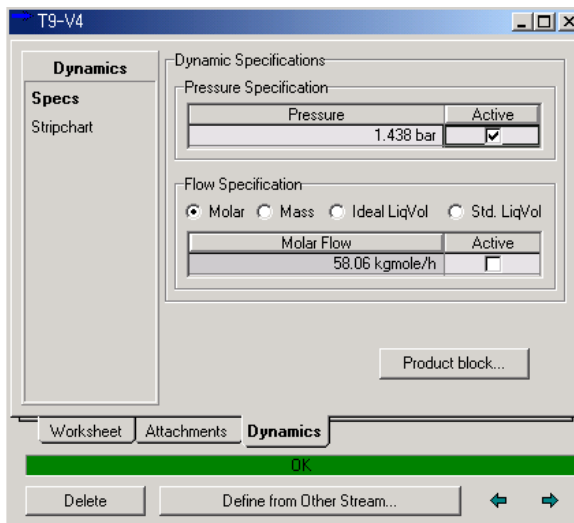

- Save your case as T9-Holding-52C-Specs.hsc.

Controllers

- Controllers can be added to the Flowsheet using the same methods as for other unit operations. The PID Controller button on the palette represents this unit operation. Once the Controller has been added to the Flowsheet.
 - Make the necessary connections for the Process Variable Source and Output Target Object.
 - Select the Minimum and Maximum values for the Process Variable. These values should bracket all possible PV values.
 - Size the valve – controller range. This is not necessary if a valve was chosen as the Output Target Object.
 - Select Controller Action, Reverse or Direct.
 - Input Controller Tuning Parameters.
 - If desired, choose the mode of the controller, Off, Manual, or Automatic.
- Add the Proposed Control Strategy for the Flash Drum System
 - Add a Flow Controller that will control the Stream TOT-NGL Flowrate to Tank T-9.

Table 2	
Controller Settings	
Connections	
Controller Name	PIC-100
Process Variable Source	Stream TOT-NGL Pressure
Output Target Variable	VLV-100
Parameters	
Action	Direct
PV Minimum	1.1 bar
PV Maximum	2.1 bar
Mode	Auto
Set Point	1.50 bar
Kc	1
Ti	5

- Insert a Controller Face Plate for monitoring by pressing the Face Plate button on the property view.

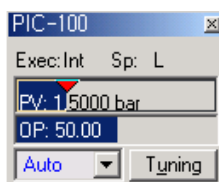

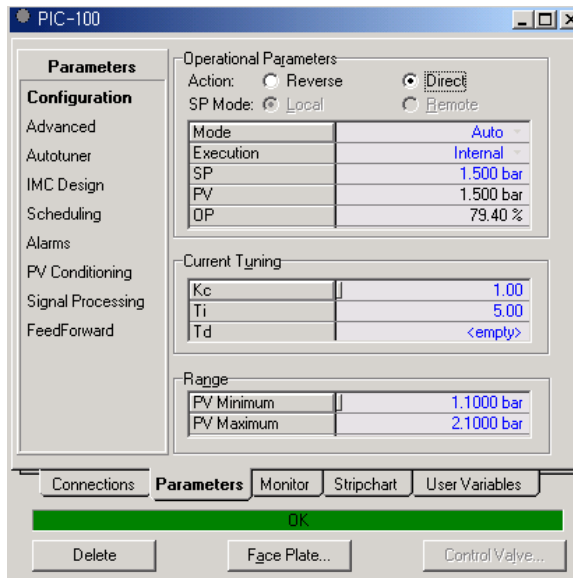
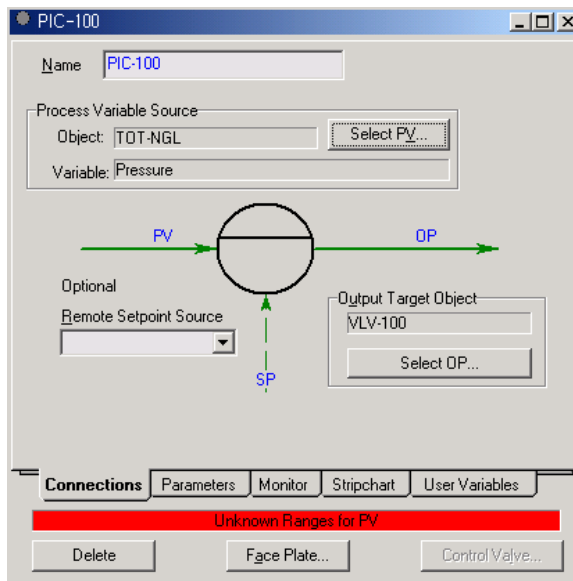

- Add another controller to control the pressure inside the Separator.

Table 3	
Controller Setting	
Connections	
Controller Name	PIC-101
Process Variable Source	Separator, T-9 Vessel Pressure
Output Target Variable	VLV-101
Parameters	
Action	Reverse
PV Minimum	0.7 bar
PV Maximum	1.7 bar
Mode	Auto
Set Point	1.032 bar
Kc	1
Ti	5

- Insert a Face Plate for Tank-PC.

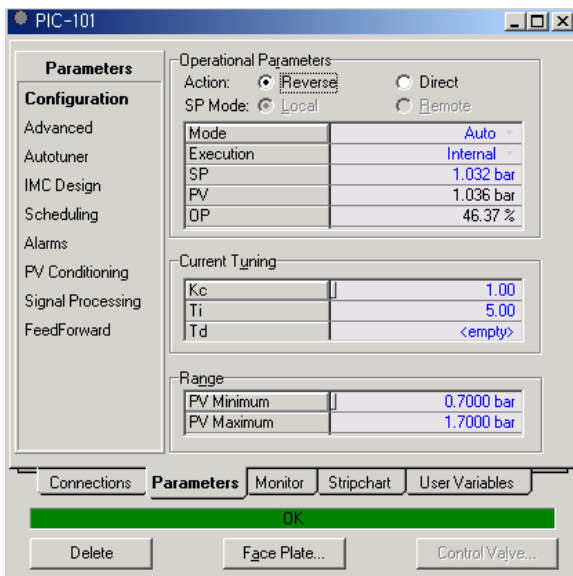
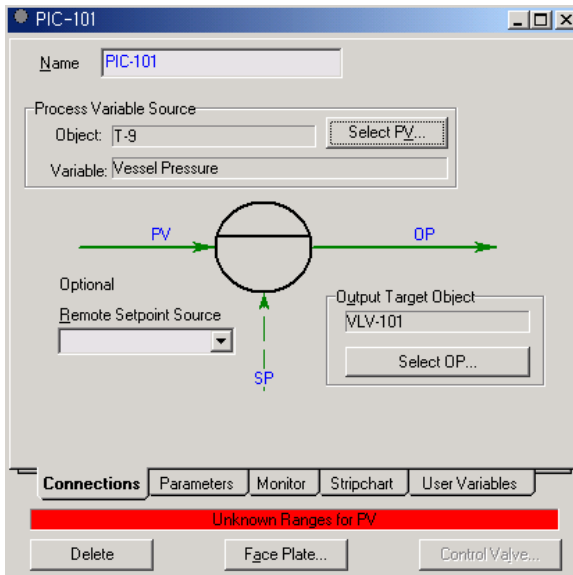
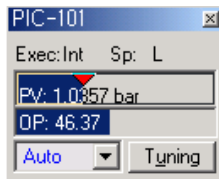

- Add a Level Controller to control the level of liquid in the tank.

Table 4	
Controller Settings	
Connections	
Controller Name	LIC-100
Process Variable Source	Separator, T-9 Liquid Percent Level
Output Target Variable	VLV-102

Parameters	
Action	Direct
PV Minimum	0 percent
PV Maximum	100 percent
Mode	Auto
Set Point	0 %
Kc	1
Ti	2

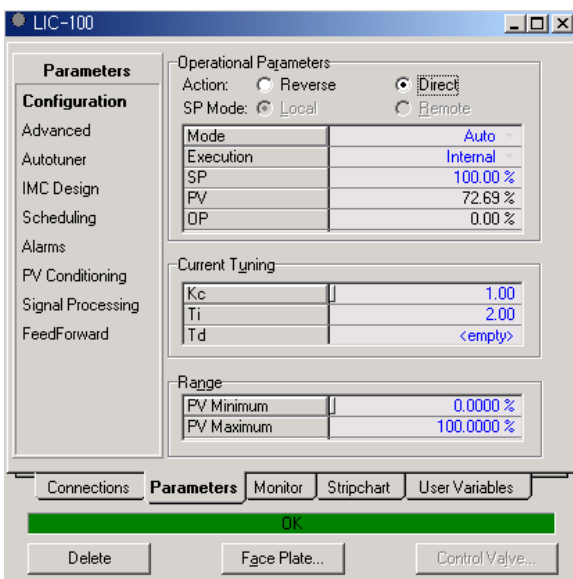
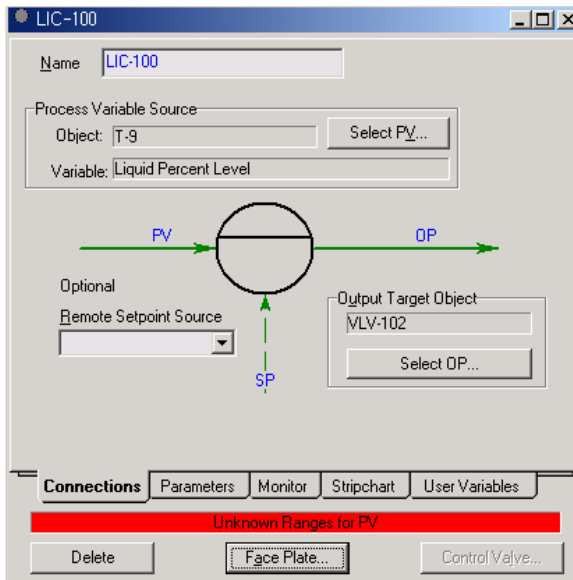
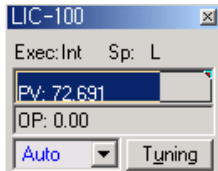

- Add a Level Controller to control the level of liquid in the tank.

Table 5	
Controller Settings	
Connections	
Controller Name	PIC-102
Process Variable Source	Stream, T9-V1 Liquid Percent Level
Output Target Variable	VLV-103
Parameters	
Action	Direct
PV Minimum	0.0981 bar
PV Maximum	2.1575 bar
Mode	Auto
Set Point	1.068 bar
Kc	1
Ti	5

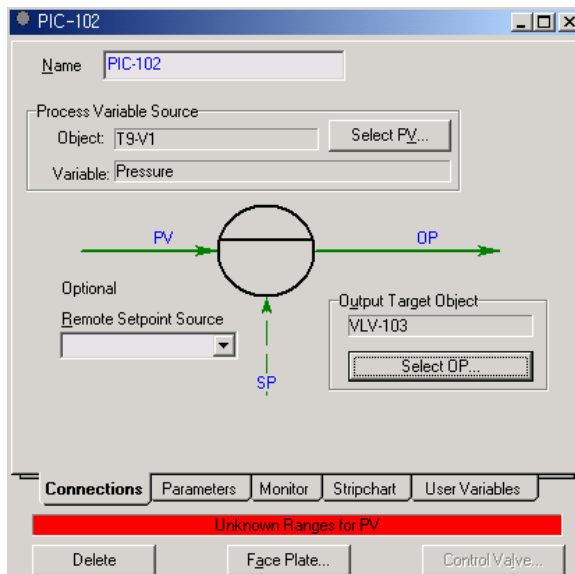

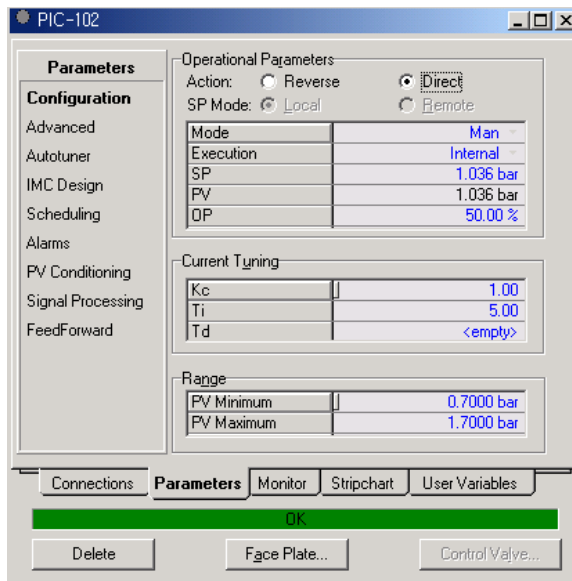

- Save your case as T9-Holding-52C-Controllers.hsc.

Strip Charts

While the Flowsheet is now running dynamically, it is difficult to observe the simulation variables. Using a strip chart allows the user to observe several variables in real time as the dynamic simulation runs.

- Press the hot key (Ctrl)<D> to create a strip chart.
- Select the Variables page and press the Insert button.
- Add the following two variables.
 - TOT-NGL Mass Flow
 - HOT-Feed Mass Flow
- Select the Strip Charts page tab.
- Change the name to Feed System.

- Add the following three variables.
 - T9-V4 Mass Flow
 - T9-V5 Mass Flow
 - T9-V6 Mass Flow
- Select the Strip Charts page tab.
- Change the name to Product Vapor Stream.

- Add the following variable.
 - LIQUID2 Mass Flow
- Select the Strip Charts page tab.
- Change the name to Product Liquid Stream.

- Add the following variable.
 - T-9 Vessel Pressure
- Select the Strip Charts page tab.
- Change the name to T9 Vessel Pressure

- Save your case as T9-Holding-52C-Dynamics-0.hsc.

View Results

- T9-V4 Stream Mass Flowrate = Nearly zero flow.
- T9-V5 Stream Mass Flowrate = 9,837.8 Kg/hr
- T9-V6 Stream Mass Flowrate = 9,743.7 Kg/hr

