

CHE302 LECTURE V
LAPLACE TRANSFORM AND
TRANSFER FUNCTION

Professor Dae Ryook Yang

Fall 2001

Dept. of Chemical and Biological Engineering
Korea University

SOLUTION OF LINEAR ODE

- **1st-order linear ODE**

- **Integrating factor:** For $\frac{dx}{dt} + a(t)x = f(x)$, I.F. = $\exp(\int a(t)dt)$

$$[xe^{\int a(t)dt}]' = f(t)e^{\int a(t)dt} \longrightarrow x(t) = [\int f(t)e^{\int a(t)dt} dt + C]e^{-\int a(t)dt}$$

- **High-order linear ODE with constant coeffs.**

- **Modes: roots of characteristic equation**

For $a_2x'' + a_1x' + a_0x = f(t)$,

$$a_2p^2 + a_1p + a_0 = a_2(p - p_1)(p - p_1) = 0$$

- **Depending on the roots, modes are**

- **Distinct roots:** (e^{-p_1t}, e^{-p_2t})
- **Double roots:** (e^{-p_1t}, te^{-p_1t})
- **Imaginary roots:** $(e^{-at} \cos bt, e^{-at} \sin bt)$

Solution is a linear combination of modes and the coefficients are decided by the initial conditions.

- **Many other techniques for different cases**

LAPLACE TRANSFORM FOR LINEAR ODE AND PDE

- **Laplace Transform**

- Not in time domain, rather in frequency domain
- Derivatives and integral become some operators.
- ODE is converted into algebraic equation
- PDE is converted into ODE in spatial coordinate
- Need inverse transform to recover time-domain solution

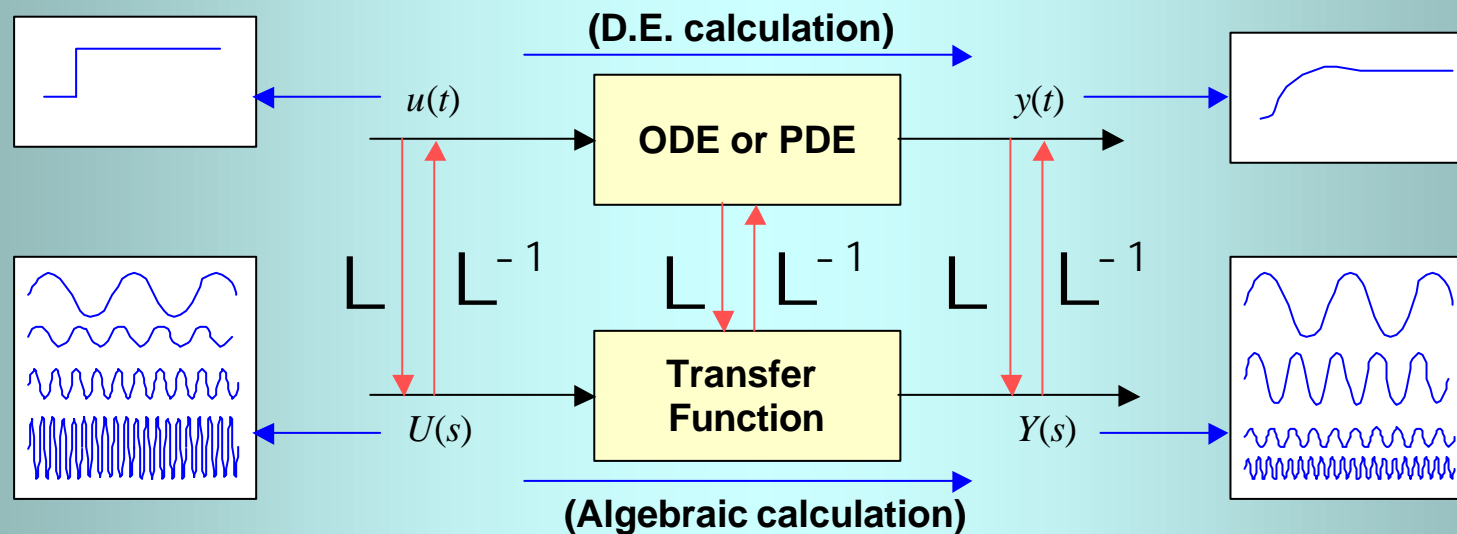

DEFINITION OF LAPLACE TRANSFORM

- **Definition**

$$F(s) = \mathcal{L}\{f(t)\} \triangleq \int_0^{\infty} f(t)e^{-st} dt$$

- $F(s)$ is called *Laplace transform* of $f(t)$.
- $f(t)$ must be piecewise continuous.
- $F(s)$ contains no information on $f(t)$ for $t < 0$.
- The past information on $f(t)$ (for $t < 0$) is irrelevant.
- The s is a complex variable called “*Laplace transform variable*”

- **Inverse Laplace transform**

$$f(t) = \mathcal{L}^{-1}\{F(s)\}$$

- \mathcal{L} and \mathcal{L}^{-1} are linear. $\mathcal{L}\{af_1(t) + bf_2(t)\} = aF_1(s) + bF_2(s)$

LAPLACE TRANSFORM OF FUNCTIONS

- **Constant function, a**

$$\mathcal{L}\{a\} = \int_0^{\infty} a e^{-st} dt = -\frac{a}{s} e^{-st} \Big|_0^{\infty} = 0 - \left(-\frac{a}{s}\right) = \frac{a}{s}$$

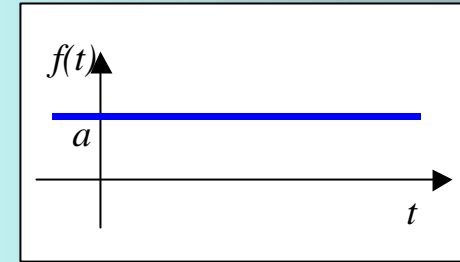

- **Step function, $S(t)$**

$$f(t) = S(t) = \begin{cases} 1 & \text{for } t \geq 0 \\ 0 & \text{for } t < 0 \end{cases}$$

$$\mathcal{L}\{S(t)\} = \int_0^{\infty} e^{-st} dt = -\frac{1}{s} e^{-st} \Big|_0^{\infty} = 0 - \left(-\frac{1}{s}\right) = \frac{1}{s}$$

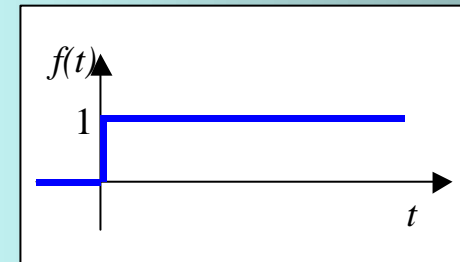

- **Exponential function, e^{-bt}**

$$\mathcal{L}\{e^{-bt}\} = \int_0^{\infty} e^{-bt} e^{-st} dt = \frac{-1}{s+b} e^{-(b+s)t} \Big|_0^{\infty} = \frac{1}{s+b}$$

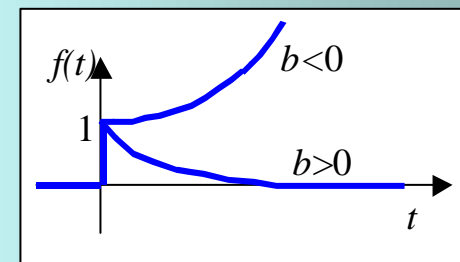

- **Trigonometric functions**

- **Euler's Identity:** $e^{j\omega t} \triangleq \cos \omega t + j \sin \omega t$

$$\cos \omega t = \frac{1}{2}(e^{j\omega t} + e^{-j\omega t}) \quad \sin \omega t = \frac{1}{2j}(e^{j\omega t} - e^{-j\omega t})$$

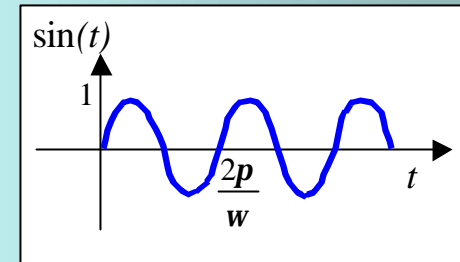

$$\mathcal{L}\{\sin \omega t\} = \mathcal{L}\left\{\frac{1}{2j}e^{j\omega t}\right\} - \mathcal{L}\left\{\frac{1}{2j}e^{-j\omega t}\right\} = \frac{1}{2j}\left(\frac{1}{s - j\omega} - \frac{1}{s + j\omega}\right) = \frac{\omega}{s^2 + \omega^2}$$

$$\mathcal{L}\{\cos \omega t\} = \mathcal{L}\left\{\frac{1}{2}e^{j\omega t}\right\} + \mathcal{L}\left\{\frac{1}{2}e^{-j\omega t}\right\} = \frac{1}{2}\left(\frac{1}{s - j\omega} + \frac{1}{s + j\omega}\right) = \frac{s}{s^2 + \omega^2}$$

- **Rectangular pulse, P(t)**

$$f(t) = P(t) = \begin{cases} 0 & \text{for } t > t_w \\ h & \text{for } t_w \geq t \geq 0 \\ 0 & \text{for } t < 0 \end{cases}$$

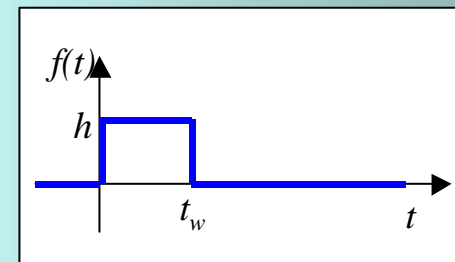

$$\mathcal{L}\{P(t)\} = \int_0^{t_w} h e^{-st} dt = -\frac{h}{s} e^{-st} \Big|_0^{t_w} = \frac{h}{s} (1 - e^{-t_w s})$$

- **Impulse function, $d(t)$**

$$f(t) = d(t) = \lim_{t_w \rightarrow 0} \begin{cases} 0 & \text{for } t > t_w \\ 1/t_w & \text{for } t_w \geq t \geq 0 \\ 0 & \text{for } t < 0 \end{cases}$$

$$\mathcal{L}\{d(t)\} = \lim_{t_w \rightarrow 0} \int_0^{t_w} \frac{1}{t_w} e^{-st} dt = \lim_{t_w \rightarrow 0} \frac{1}{t_w s} (1 - e^{-t_w s}) = 1$$

$$\left(\text{L'Hospital's rule: } \lim_{t \rightarrow 0} \frac{f(t)}{g(t)} = \lim_{t \rightarrow 0} \frac{f'(t)}{g'(t)} \right)$$

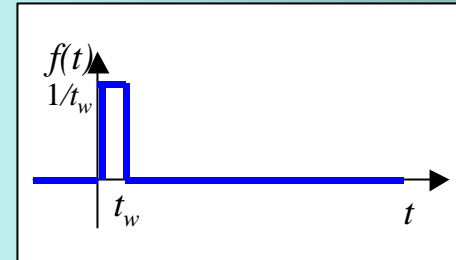

- **Ramp function, t**

$$\mathcal{L}\{t\} = \int_0^{\infty} t e^{-st} dt$$

$$= \frac{t}{-s} e^{-st} \Big|_0^{\infty} - \int_0^{\infty} \frac{e^{-st}}{-s} dt = \frac{1}{s} \int_0^{\infty} e^{-st} dt = \frac{1}{s^2}$$

$$\left(\text{Integration by part: } \int_0^{\infty} f' \cdot g dt = f \cdot g \Big|_0^{\infty} - \int_0^{\infty} f \cdot g' dt \right)$$

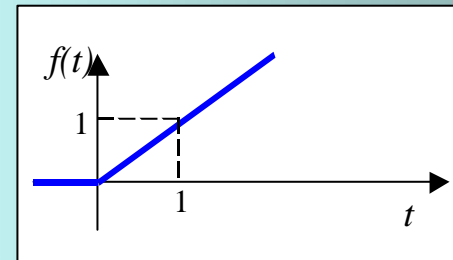

- **Refer the Table 3.1 (Seborg et al.) for other functions**

Table 3.1 Laplace Transforms for Various Time-Domain Functions*

	$f(t)$	$F(s)$
1.	$\delta(t)$ (unit impulse)	1
2.	$S(t)$ (unit step)	$\frac{1}{s}$
3.	t (ramp)	$\frac{1}{s^2}$
4.	t^{n-1}	$\frac{(n-1)!}{s^n}$
5.	e^{-bt}	$\frac{1}{s+b}$
6.	$\frac{1}{\tau} e^{-t/\tau}$	$\frac{1}{\tau s + 1}$
7.	$\frac{t^{n-1} e^{-bt}}{(n-1)!}$ ($n > 0$)	$\frac{1}{(s+b)^n}$
8.	$\frac{1}{\tau^n (n-1)!} t^{n-1} e^{-t/\tau}$	$\frac{1}{(\tau s + 1)^n}$
9.	$\frac{1}{b_1 - b_2} (e^{-b_2 t} - e^{-b_1 t})$	$\frac{1}{(s+b_1)(s+b_2)}$
10.	$\frac{1}{\tau_1 - \tau_2} (e^{-t/\tau_1} - e^{-t/\tau_2})$	$\frac{1}{(\tau_1 s + 1)(\tau_2 s + 1)}$
11.	$\frac{b_3 - b_1}{b_2 - b_1} e^{-b_1 t} + \frac{b_3 - b_2}{b_1 - b_2} e^{-b_2 t}$	$\frac{s + b_3}{(s + b_1)(s + b_2)}$
12.	$\frac{1}{\tau_1 \tau_1 - \tau_2} e^{-t/\tau_1} + \frac{1}{\tau_2 \tau_2 - \tau_1} e^{-t/\tau_2}$	$\frac{\tau_3 s + 1}{(\tau_1 s + 1)(\tau_2 s + 1)}$
13.	$1 - e^{-t/\tau}$	$\frac{1}{s(\tau s + 1)}$
14.	$\sin \omega t$	$\frac{\omega}{s^2 + \omega^2}$

Table 3.1 (Continued)

$f(t)$	$F(s)$
15. $\cos \omega t$	$\frac{s}{s^2 + \omega^2}$
16. $\sin (\omega t + \phi)$	$\frac{\omega \cos \phi + s \sin \phi}{s^2 + \omega^2}$
17. $e^{-bt} \sin \omega t$	$\left. \begin{array}{l} \frac{\omega}{(s + b)^2 + \omega^2} \\ \frac{s + b}{(s + b)^2 + \omega^2} \\ \frac{1}{\tau^2 s^2 + 2\zeta\tau s + 1} \end{array} \right\} \begin{array}{l} b, \omega \text{ real} \\ \\ \end{array}$
18. $e^{-bt} \cos \omega t$	
19. $\frac{1}{\tau\sqrt{1-\zeta^2}} e^{-\zeta t/\tau} \sin(\sqrt{1-\zeta^2} t/\tau)$ ($0 \leq \zeta < 1$)	$\frac{1}{\tau^2 s^2 + 2\zeta\tau s + 1}$
20. $1 + \frac{1}{\tau_2 - \tau_1} (\tau_1 e^{-t/\tau_1} - \tau_2 e^{-t/\tau_2})$ ($\tau_1 \neq \tau_2$)	$\frac{1}{s(\tau_1 s + 1)(\tau_2 s + 1)}$
21. $1 - \frac{1}{\sqrt{1-\zeta^2}} e^{-\zeta t/\tau} \sin[\sqrt{1-\zeta^2} t/\tau + \psi]$ $\psi = \tan^{-1} \frac{\sqrt{1-\zeta^2}}{\zeta}$ ($0 \leq \zeta < 1$)	$\frac{1}{s(\tau^2 s^2 + 2\zeta\tau s + 1)}$
22. $1 - e^{-\zeta t/\tau} [\cos(\sqrt{1-\zeta^2} t/\tau) + \frac{\zeta}{1-\zeta^2} \sin(\sqrt{1-\zeta^2} t/\tau)]$ ($0 \leq \zeta < 1$)	$\frac{1}{s(\tau^2 s^2 + 2\zeta\tau s + 1)}$
23. $1 + \frac{\tau_3 - \tau_1}{\tau_1 - \tau_2} e^{-t/\tau_1} + \frac{\tau_3 - \tau_2}{\tau_2 - \tau_1} e^{-t/\tau_2}$ ($\tau_1 \neq \tau_2$)	$\frac{\tau_3 s + 1}{s(\tau_1 s + 1)(\tau_2 s + 1)}$
24. $\frac{df}{dt}$	$sF(s) - f(0)$
25. $\frac{d^n f}{dt^n}$	$s^n F(s) - s^{n-1} f(0) - s^{n-2} f'(0) - \dots - s f^{(n-2)}(0) - f^{(n-1)}(0)$

^aNote that $f(t)$ and $F(s)$ are defined for $t \geq 0$ only.

PROPERTIES OF LAPLACE TRANSFORM

- **Differentiation**

$$\begin{aligned}\mathcal{L}\left\{\frac{df}{dt}\right\} &= \int_0^{\infty} f' \cdot e^{-st} dt = f(t)e^{-st} \Big|_0^{\infty} - \int_0^{\infty} f \cdot (-s)e^{-st} dt \quad (\text{by i.b.p.}) \\ &= s \int_0^{\infty} f \cdot e^{-st} dt - f(0) = sF(s) - f(0)\end{aligned}$$

$$\begin{aligned}\mathcal{L}\left\{\frac{d^2f}{dt^2}\right\} &= \int_0^{\infty} f'' \cdot e^{-st} dt = f'(t)e^{-st} \Big|_0^{\infty} - \int_0^{\infty} f' \cdot (-s)e^{-st} dt = s \int_0^{\infty} f' \cdot e^{-st} dt - f'(0) \\ &= s(sF(s) - f(0)) - f'(0) = s^2F(s) - sf(0) - f'(0) \\ &\vdots\end{aligned}$$

$$\begin{aligned}\mathcal{L}\left\{\frac{d^n f}{dt^n}\right\} &= \int_0^{\infty} f^{(n)} \cdot e^{-st} dt = f^{(n-1)}(t)e^{-st} \Big|_0^{\infty} - \int_0^{\infty} f^{(n-1)} \cdot (-s)e^{-st} dt \\ &= s \int_0^{\infty} f^{(n-1)} \cdot e^{-st} dt - f^{(n-1)}(0) = s \left(\mathcal{L}\left\{\frac{d^{n-1}f}{dt^{n-1}}\right\} \right) - f^{(n-1)}(0) \\ &= s^n F(s) - s^{n-1}f(0) - \dots - sf^{(n-2)}(0) - f^{(n-1)}(0)\end{aligned}$$

- **If $f(0) = f'(0) = f''(0) = \dots = f^{(n-1)}(0) = 0$,**
 - **Initial condition effects are vanished.**
 - **It is very convenient to use **deviation variables** so that all the effects of initial condition vanish.**

$$\begin{aligned} \mathcal{L} \left\{ \frac{df}{dt} \right\} &= sF(s) \\ \mathcal{L} \left\{ \frac{d^2 f}{dt^2} \right\} &= s^2 F(s) \\ &\vdots \\ \mathcal{L} \left\{ \frac{d^n f}{dt^n} \right\} &= s^n F(s) \end{aligned}$$

- **Transforms of linear differential equations.**

$$y(t) \xrightarrow{\mathcal{L}} Y(s), \quad u(t) \xrightarrow{\mathcal{L}} U(s)$$

$$\frac{dy(t)}{dt} \xrightarrow{\mathcal{L}} sY(s) \quad (\text{if } y(0) = 0)$$

$$t \frac{dy(t)}{dt} = -y(t) + Ku(t) \quad (y(0) = 0) \xrightarrow{\mathcal{L}} (ts + 1)Y(s) = KU(s)$$

$$\frac{\partial T_L}{\partial t} = -v \frac{\partial T_L}{\partial z} + \frac{1}{t_{HL}} (T_w - T_L) \xrightarrow{\mathcal{L}} t_{HL} v \frac{\partial \tilde{T}_L(s)}{\partial z} + (t_{HL} s + 1) \tilde{T}_L(s) = \tilde{T}_w(s)$$

- **Integration**

$$\begin{aligned} \mathcal{L}\left\{\int_0^t f(\mathbf{x})d\mathbf{x}\right\} &= \int_0^\infty \left(\int_0^t f(\mathbf{x})d\mathbf{x}\right)e^{-st} dt \\ &= \frac{e^{-st}}{-s} \int_0^t f(\mathbf{x})d\mathbf{x} \Big|_0^\infty + \frac{1}{s} \int_0^\infty f \cdot e^{-st} dt = \frac{F(s)}{s} \quad (\text{by } i.b.p.) \end{aligned}$$

$$\left(\text{Leibniz rule: } \frac{d}{dt} \int_{a(t)}^{b(t)} f(t)dt = f(b(t)) \frac{db(t)}{dt} - f(a(t)) \frac{da(t)}{dt} \right)$$

- **Time delay (Translation in time)**

$$f(t) \xrightarrow{+q \text{ in } t} f(t-q)S(t-q)$$

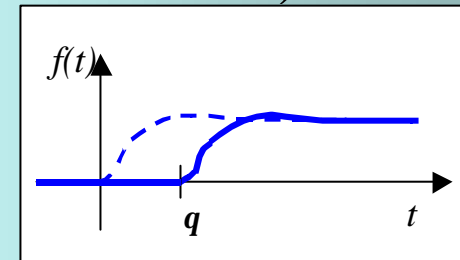

$$\begin{aligned} \mathcal{L}\{f(t-q)S(t-q)\} &= \int_q^\infty f(t-q)e^{-st} dt = \int_0^\infty f(\mathbf{t})e^{-s(\mathbf{t}+q)} d\mathbf{t} \quad (\text{let } \mathbf{t} = t-q) \\ &= e^{-qs} \int_0^\infty f(\mathbf{t})e^{-\mathbf{t}s} d\mathbf{t} = e^{-qs} F(s) \end{aligned}$$

- **Derivative of Laplace transform**

$$\frac{dF(s)}{ds} = \frac{d}{ds} \int_0^\infty f \cdot e^{-st} dt = \int_0^\infty f \cdot \frac{d}{ds} e^{-st} dt = \int_0^\infty (-t \cdot f) e^{-st} dt = \mathcal{L}[-t \cdot f(t)]$$

- **Final value theorem**

- From the LT of differentiation, as s approaches to zero

$$\lim_{s \rightarrow 0} \int_0^{\infty} \frac{df}{dt} \cdot e^{-st} dt = \lim_{s \rightarrow 0} [sF(s) - f(0)]$$

$$\int_0^{\infty} \frac{df}{dt} dt = f(\infty) - f(0) = \lim_{s \rightarrow 0} sF(s) - f(0) \Rightarrow f(\infty) = \lim_{s \rightarrow 0} sF(s)$$

- **Limitation:** $f(\infty)$ has to exist. If it diverges or oscillates, this theorem is not valid.

- **Initial value theorem**

- From the LT of differentiation, as s approaches to infinity

$$\lim_{s \rightarrow \infty} \int_0^{\infty} \frac{df}{dt} \cdot e^{-st} dt = \lim_{s \rightarrow \infty} [sF(s) - f(0)]$$

$$\lim_{s \rightarrow \infty} \int_0^{\infty} \frac{df}{dt} e^{-st} dt = 0 = \lim_{s \rightarrow \infty} sF(s) - f(0) \Rightarrow f(0) = \lim_{s \rightarrow \infty} sF(s)$$

EXAMPLE ON LAPLACE TRANSFORM (1)

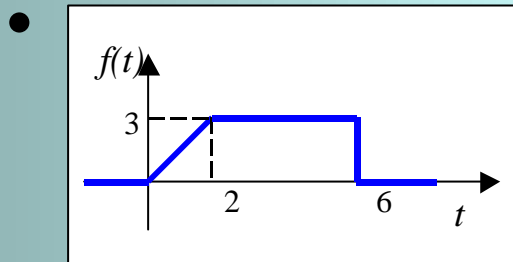

$$f(t) = \begin{cases} 1.5t & \text{for } 0 \leq t < 2 \\ 3 & \text{for } 2 \leq t < 6 \\ 0 & \text{for } 6 \leq t \\ 0 & \text{for } t < 0 \end{cases}$$

$$f(t) = 1.5tS(t) - 1.5(t-2)S(t-2) - 3S(t-6)$$

$$\therefore F(s) = \mathcal{L}\{f(t)\} = \frac{1.5}{s^2}(1 - e^{-2s}) - \frac{3}{s}e^{-6s}$$

- For $F(s) = \frac{2}{s-5}$, find $f(0)$ and $f(\infty)$.

- Using the initial and final value theorems

$$f(0) = \lim_{s \rightarrow \infty} sF(s) = \lim_{s \rightarrow \infty} \frac{2s}{s-5} = 2 \quad f(\infty) = \lim_{s \rightarrow 0} sF(s) = \lim_{s \rightarrow 0} \frac{2s}{s-5} = 0$$

- But the final value theorem is not valid because

$$\lim_{t \rightarrow \infty} f(t) = \lim_{t \rightarrow \infty} 2e^{5t} = \infty$$

EXAMPLE ON LAPLACE TRANSFORM (2)

- What is the final value of the following system?

$$x'' + x' + x = \sin t; \quad x(0) = x'(0) = 0$$

$$\Rightarrow s^2 X(s) + sX(s) + X = \frac{1}{s^2 + 1} \Rightarrow x(s) = \frac{1}{(s^2 + 1)(s^2 + s + 1)}$$

$$x(\infty) \stackrel{\text{no}}{=} \lim_{s \rightarrow 0} \frac{s}{(s^2 + 1)(s^2 + s + 1)} = 0$$

– Actually, $x(\infty)$ cannot be defined due to $\sin t$ term.

- Find the Laplace transform for $(t \sin wt)$?

$$\text{From } \frac{dF(s)}{ds} = \mathcal{L}[-t \cdot f(t)]$$

$$\mathcal{L}[t \cdot \sin wt] = -\frac{d}{ds} \left[\frac{w}{s^2 + w^2} \right] = \frac{2ws}{(s^2 + w^2)^2}$$

INVERSE LAPLACE TRANSFORM

- **Used to recover the solution in time domain**

$$\mathcal{L}^{-1}\{F(s)\} = f(t)$$

- **From the table**
- **By partial fraction expansion**
- **By inversion using contour integral**

$$f(t) = \mathcal{L}^{-1}\{F(s)\} = \frac{1}{2\pi j} \oint_C e^{st} F(s) ds$$

- **Partial fraction expansion**

- **After the partial fraction expansion, it requires to know some simple formula of inverse Laplace transform such as**

$$\frac{1}{(ts+1)}, \frac{s}{(s+b)^2 + w^2}, \frac{(n-1)!}{s^n}, \frac{e^{-qs}}{t^2 s^2 + 2zts + 1}, \text{ etc.}$$

PARTIAL FRACTION EXPANSION

$$F(s) = \frac{N(s)}{D(s)} = \frac{N(s)}{(s + p_1) \cdots (s + p_n)} = \frac{a_1}{(s + p_1)} + \cdots + \frac{a_n}{(s + p_n)}$$

- **Case I: All p_i 's are distinct and real**
 - By a root-finding technique, find all roots (time-consuming)
 - Find the coefficients for each fraction
 - Comparison of the coefficients after multiplying the denominator
 - Replace some values for s and solve linear algebraic equation
 - Use of Heaviside expansion
 - Multiply both side by a factor, $(s+p_i)$, and replace s with $-p_i$.

$$a_i = (s + p_i) \left. \frac{N(s)}{D(s)} \right|_{s=-p_i}$$

- Inverse LT:

$$f(t) = a_1 e^{-p_1 t} + a_2 e^{-p_2 t} + \cdots + a_n e^{-p_n t}$$

- **Case II: Some roots are repeated**

$$F(s) = \frac{N(s)}{D(s)} = \frac{N(s)}{(s+p)^r} = \frac{b_{r-1}s^{r-1} + \dots + b_0}{(s+p)^r} = \frac{\mathbf{a}_1}{(s+p)} + \dots + \frac{\mathbf{a}_r}{(s+p)^r}$$

- **Each repeated factors have to be separated first.**
- **Same methods as Case I can be applied.**
- **Heaviside expansion for repeated factors**

$$\mathbf{a}_{r-i} = \frac{1}{i!} \frac{d^{(i)}}{ds^{(i)}} \left(\frac{N(s)}{D(s)} (s+p)^r \right) \Bigg|_{s=-p} \quad (i = 0, \dots, r-1)$$

- **Inverse LT**

$$f(t) = \mathbf{a}_1 e^{-pt} + \mathbf{a}_2 t e^{-pt} + \dots + \frac{\mathbf{a}_r}{(r-1)!} t^{r-1} e^{-pt}$$

- **Case III: Some roots are complex**

$$F(s) = \frac{N(s)}{D(s)} = \frac{c_1s + c_0}{s^2 + d_1s + d_0} = \frac{\mathbf{a}_1(s + b) + \mathbf{b}_1\mathbf{w}}{(s + b)^2 + \mathbf{w}^2}$$

- Each repeated factors have to be separated first.
- Then,

$$\frac{\mathbf{a}_1(s + b) + \mathbf{b}_1\mathbf{w}}{(s + b)^2 + \mathbf{w}^2} = \mathbf{a}_1 \frac{(s + b)}{(s + b)^2 + \mathbf{w}^2} + \mathbf{b}_1 \frac{\mathbf{w}}{(s + b)^2 + \mathbf{w}^2}$$

where $b = d_1 / 2$, $\mathbf{w} = \sqrt{d_0 - d_1^2 / 4}$

$$\mathbf{a}_1 = c_1, \quad \mathbf{b}_1 = (c_0 - \mathbf{a}_1b) / \mathbf{w}$$

- Inverse LT

$$f(t) = \mathbf{a}_1 e^{-bt} \cos \mathbf{w}t + \mathbf{b}_1 e^{-bt} \sin \mathbf{w}t$$

EXAMPLES ON INVERSE LAPLACE TRANSFORM

- $$F(s) = \frac{(s+5)}{s(s+1)(s+2)(s+3)} = \frac{A}{s} + \frac{B}{s+1} + \frac{C}{s+2} + \frac{D}{s+3} \quad (\text{distinct})$$

– **Multiply each factor and insert the zero value**

$$\left. \frac{(s+5)}{(s+1)(s+2)(s+3)} \right|_{s=0} = \left(A + s \frac{B}{s+1} + s \frac{C}{s+2} + s \frac{D}{s+3} \right) \Big|_{s=0} \Rightarrow A = 5/6$$

$$\left. \frac{(s+5)}{s(s+2)(s+3)} \right|_{s=-1} = \left(\frac{A(s+1)}{s} + B + \frac{C(s+1)}{s+2} + \frac{D(s+1)}{s+3} \right) \Big|_{s=-1} \Rightarrow B = -2$$

$$\left. \frac{(s+5)}{s(s+1)(s+3)} \right|_{s=-2} = \left(\frac{A(s+2)}{s} + \frac{B(s+2)}{s+1} + C + \frac{D(s+2)}{s+3} \right) \Big|_{s=-2} \Rightarrow C = 3/2$$

$$\left. \frac{(s+5)}{s(s+1)(s+2)} \right|_{s=-3} = \left(\frac{A(s+3)}{s} + \frac{B(s+3)}{s+1} + \frac{C(s+3)}{s+2} + D \right) \Big|_{s=-3} \Rightarrow D = -1/3$$

$$\therefore f(t) = \mathcal{L}^{-1}\{F(s)\} = \frac{5}{6} - 2e^{-t} + \frac{3}{2}e^{-2t} - \frac{1}{3}e^{-3t}$$

- $$F(s) = \frac{1}{(s+1)^3(s+2)} = \frac{As^2 + Bs + C}{(s+1)^3} + \frac{D}{(s+2)} \quad (\text{repeated})$$

$$1 = (As^2 + Bs + C)(s+2) + D(s+1)^3$$

$$= (A+D)s^3 + (2A+B+3D)s^2 + (2B+C+3D)s + (2C+D)$$

$$\therefore A = -D, \quad 2A + B + 3D = 0, \quad 2B + C + 3D = 0, \quad 2C + D = 1$$

$$\Rightarrow A = 1, \quad B = 1, \quad C = 1, \quad D = -1$$

- Use of Heaviside expansion** $a_{r-i} = \frac{1}{i!} \frac{d^{(i)}}{ds^{(i)}} \left(\frac{N(s)}{D(s)} (s+p)^r \right) \Big|_{s=-p} \quad (i = 0, \dots, r-1)$

$$\frac{s^2 + s + 1}{(s+1)^3} = \frac{\mathbf{a}_1}{(s+1)} + \frac{\mathbf{a}_2}{(s+1)^2} + \frac{\mathbf{a}_3}{(s+1)^3}$$

$$(i=0): \mathbf{a}_3 = (s^2 + s + 1) \Big|_{s=-1} = 1$$

$$(i=1): \mathbf{a}_2 = \frac{1}{1!} \frac{d}{ds} (s^2 + s + 1) \Big|_{s=-1} = -1$$

$$(i=2): \mathbf{a}_1 = \frac{1}{2!} \frac{d^2}{ds^2} (s^2 + s + 1) \Big|_{s=-1} = 1$$

$$\therefore f(t) = \mathcal{L}^{-1}\{F(s)\} = e^{-t} - te^{-t} + \frac{1}{2}t^2e^{-t} - e^{-2t}$$

- $$F(s) = \frac{(s+1)}{s^2(s^2+4s+5)} = \frac{A(s+2)+B}{(s+2)^2+1} + \frac{Cs+D}{s^2} \quad (\text{complex})$$

$$\begin{aligned} s+1 &= A(s+2)s^2 + Bs^2 + (Cs+D)(s^2+4s+5) \\ &= (A+C)s^3 + (2A+B+4C+D)s^2 + (5C+4D)s + 5D \end{aligned}$$

$$\therefore A = -C, \quad 2A + B + 4C + D = 0, \quad 5C + 4D = 1, \quad 5D = 1$$

$$\Rightarrow A = -1/25, \quad B = -7/25, \quad C = 1/25, \quad D = 1/5$$

$$\frac{A(s+2)+B}{(s+2)^2+1} = -\frac{1}{25} \frac{(s+2)}{(s+2)^2+1} - \frac{7}{25} \frac{B}{(s+2)^2+1}$$

$$\frac{Cs+D}{s^2} = \frac{1}{25} \frac{1}{s} + \frac{1}{5} \frac{1}{s^2}$$

$$\therefore f(t) = \mathcal{L}^{-1}\{F(s)\} = -\frac{1}{25} e^{-2t} \cos t - \frac{7}{25} e^{-2t} \sin t + \frac{1}{25} + \frac{1}{5} t$$

- $$F(s) = \frac{1 + e^{-2s}}{(4s + 1)(3s + 1)} = \left(\frac{A}{4s + 1} + \frac{B}{3s + 1} \right) (1 + e^{-2s}) \quad (\text{Time delay})$$

$$A = 1/(3s + 1)|_{s=-1/4} = 4, \quad B = 1/(4s + 1)|_{s=-1/3} = -3$$

$$\begin{aligned} \therefore f(t) &= \mathcal{L}^{-1}\{F(s)\} = \mathcal{L}^{-1}\left\{\frac{4}{4s + 1} - \frac{3}{3s + 1}\right\} + \mathcal{L}^{-1}\left\{\frac{4e^{-2s}}{4s + 1} - \frac{3e^{-2s}}{3s + 1}\right\} \\ &= e^{-t/4} - e^{-t/3} + \left(e^{-(t-2)/4} - e^{-(t-2)/3}\right)S(t-2) \end{aligned}$$



**It is a brain teaser!!!
But you have to live with it.**

**Hang on!!!
You are half way there.**



SOLVING ODE BY LAPLACE TRANSFORM

- **Procedure**

1. **Given linear ODE with initial condition,**
2. **Take Laplace transform and solve for output**
3. **Inverse Laplace transform**

- **Example:** Solve for $5\frac{dy}{dt} + 4y = 2; y(0) = 1$

$$\mathcal{L}\left\{5\frac{dy}{dt}\right\} + \mathcal{L}\{4y\} = \mathcal{L}\{2\} \Rightarrow 5(sY(s) - y(0)) + 4Y(s) = \frac{2}{s}$$

$$(5s + 4)Y(s) = \frac{2}{s} + 5 \Rightarrow Y(s) = \frac{5s + 2}{s(5s + 4)}$$

$$\therefore y(t) = \mathcal{L}^{-1}\{Y(s)\} = \mathcal{L}^{-1}\left\{\frac{0.5}{s} + \frac{2.5}{5s + 4}\right\} = 0.5 + 0.5e^{-0.8t}$$

TRANSFER FUNCTION (1)

- **Definition**

- An algebraic expression for the dynamic relation **between the input and output** of the process model

$$5 \frac{dy}{dt} + 4y = u; y(0) = 1$$

$$\text{Let } \tilde{y} = y - 1 \text{ and } \tilde{u} = u - 4$$

$$(5s + 4)\tilde{Y}(s) = \tilde{U}(s) \Rightarrow \frac{\tilde{Y}(s)}{\tilde{U}(s)} = \frac{1}{5s + 4} = \frac{0.25}{1.25s + 1} = G(s)$$

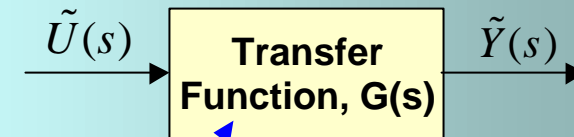

- **How to find transfer function**

1. Find the **equilibrium point**
2. If the system is nonlinear, then **linearize** around equil. point
3. Introduce **deviation variables**
4. Take **Laplace transform** and solve for output
5. Do the **Inverse Laplace transform** and recover the original variables from deviation variables

TRANSFER FUNCTION (2)

- **Benefits**

- Once TF is known, the output response to various given inputs can be obtained easily.

$$y(t) = \mathcal{L}^{-1}\{Y(s)\} = \mathcal{L}^{-1}\{G(s)U(s)\} \neq \mathcal{L}^{-1}\{G(s)\} \mathcal{L}^{-1}\{U(s)\}$$

- Interconnected system can be analyzed easily.

- By block diagram algebra

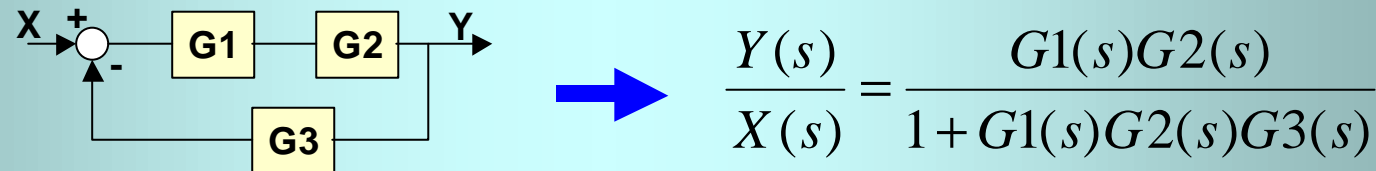

- Easy to analyze the qualitative behavior of a process, such as stability, speed of response, oscillation, etc.
 - By inspecting “Poles” and “Zeros”
 - Poles: all s 's satisfying $D(s)=0$
 - Zeros: all s 's satisfying $N(s)=0$

TRANSFER FUNCTION (3)

- **Steady-state Gain:** The ratio between ultimate changes in input and output

$$\text{Gain}=K = \frac{\Delta \text{output}}{\Delta \text{input}} = \frac{(y(\infty) - y(0))}{(u(\infty) - u(0))}$$

- For a unit step change in input, the gain is the change in output
- Gain may not be definable: for example, integrating processes and processes with sustaining oscillation in output
- From the final value theorem, unit step change in input with zero initial condition gives

$$K = \frac{y(\infty)}{1} = \lim_{s \rightarrow 0} sY(s) = \lim_{s \rightarrow 0} sG(s) \frac{1}{s} = \lim_{s \rightarrow 0} G(s)$$

- The transfer function itself is an impulse response of the system $Y(s) = G(s)U(s) = G(s)\mathcal{L}\{d(t)\} = G(s)$

EXAMPLE

- **Horizontal cylindrical storage tank (Ex4.7)**

$$\frac{dm}{dt} = r \frac{dV}{dt} = r q_i - r q$$

$$V(h) = \int_0^h L w_i(\tilde{h}) d\tilde{h} \Rightarrow \frac{dV}{dt} = L w_i(h) \frac{dh}{dt}$$

$$w_i(h) / 2 = \sqrt{R^2 + (R-h)^2} = \sqrt{(2R-h)h}$$

$$w_i L \frac{dh}{dt} = q_i - q \Rightarrow \frac{dh}{dt} = \frac{1}{2L\sqrt{(D-h)h}} (q_i - q) \quad (\text{Nonlinear ODE})$$

- **Equilibrium point:** $(\bar{q}_i, \bar{q}, \bar{h}) \quad 0 = (\bar{q}_i - \bar{q}) / (2L\sqrt{(D-\bar{h})\bar{h}})$
(if $\bar{q}_i = \bar{q}$, \bar{h} can be any value in $0 \leq \bar{h} \leq D$.)

- **Linearization:**

$$\frac{dh}{dt} = f(h, q_i, q) = \left. \frac{\partial f}{\partial h} \right|_{(\bar{h}, \bar{q}_i, \bar{q})} (h - \bar{h}) + \left. \frac{\partial f}{\partial q_i} \right|_{(\bar{h}, \bar{q}_i, \bar{q})} (q_i - \bar{q}_i) + \left. \frac{\partial f}{\partial q} \right|_{(\bar{h}, \bar{q}_i, \bar{q})} (q - \bar{q})$$

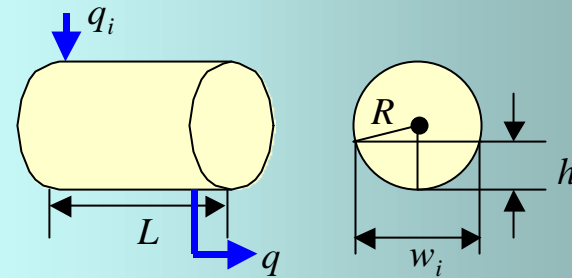

$$\left. \frac{\partial f}{\partial h} \right|_{(\bar{h}, \bar{q}_i, \bar{q})} = (\bar{q}_i - \bar{q}) \frac{\partial}{\partial h} \frac{-1}{2L\sqrt{(D-h)h}} = 0 \quad (\because \bar{q}_i = \bar{q})$$

$$\left. \frac{\partial f}{\partial q} \right|_{(\bar{h}, \bar{q}_i, \bar{q})} = \frac{-1}{2L\sqrt{(D-h)h}}, \quad \left. \frac{\partial f}{\partial q_i} \right|_{(\bar{h}, \bar{q}_i, \bar{q})} = \frac{1}{2L\sqrt{(D-h)h}}$$

Let this term be k

$$s\tilde{H}(s) = k\tilde{Q}_i(s) - k\tilde{Q}(s)$$

- Transfer function between $\tilde{H}(s)$ and $\tilde{Q}(s)$: $-\frac{k}{s}$ (integrating)
- Transfer function between $\tilde{H}(s)$ and $\tilde{Q}_i(s)$: $\frac{k}{s}$ (integrating)
- If \bar{h} is near 0 or D , k becomes very large and \bar{h} is around $\bar{h}/2$, k becomes minimum.

P The model could be quite different depending on the operating condition used for the linearization.

P The best suitable range for the linearization in this case is around $\bar{h}/2$. (less change in gain)

P Linearized model would be valid in very narrow range near 0

PROPERTIES OF TRANSFER FUNCTION

- **Additive property**

$$\begin{aligned} Y(s) &= Y_1(s) + Y_2(s) \\ &= G_1(s)X_1(s) + G_2(s)X_2(s) \end{aligned}$$

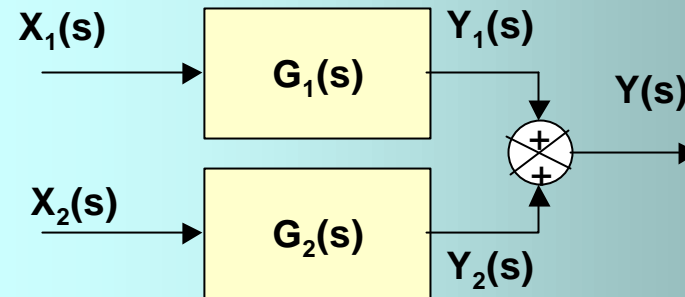

- **Multiplicative property**

$$\begin{aligned} X_3(s) &= G_2(s)X_2(s) \\ &= G_2(s)[G_1(s)X_1(s)] = G_2(s)G_1(s)X_1(s) \end{aligned}$$

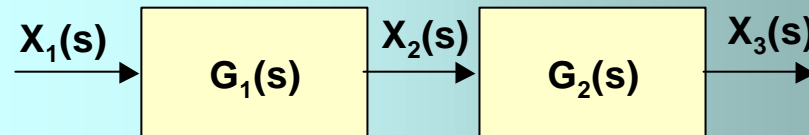

- **Physical realizability**

- In a transfer function, the order of numerator(m) is greater than that of denominator(n): called “**physically unrealizable**”
- The order of derivative for the input is higher than that of output. (requires future input values for current output)

EXAMPLES ON TWO TANK SYSTEM

- **Two tanks in series (Ex3.7)**

- No reaction

$$V_1 \frac{dc_1}{dt} + qc_1 = qc_i$$

$$V_2 \frac{dc_2}{dt} + qc_2 = qc_1$$

- **Initial condition:** $c_1(0) = c_2(0) = 1 \text{ kg mol/m}^3$ (Use deviation var.)

- **Parameters:** $V_1/q = 2 \text{ min.}$, $V_2/q = 1.5 \text{ min.}$

- **Transfer functions**

$$\frac{\tilde{C}_1(s)}{\tilde{C}_i(s)} = \frac{1}{(V_1/q)s + 1} \quad \frac{\tilde{C}_2(s)}{\tilde{C}_1(s)} = \frac{1}{(V_2/q)s + 1}$$

$$\frac{\tilde{C}_2(s)}{\tilde{C}_i(s)} = \frac{\tilde{C}_2(s)}{\tilde{C}_1(s)} \frac{\tilde{C}_1(s)}{\tilde{C}_i(s)} = \frac{1}{((V_2/q)s + 1)((V_1/q)s + 1)}$$

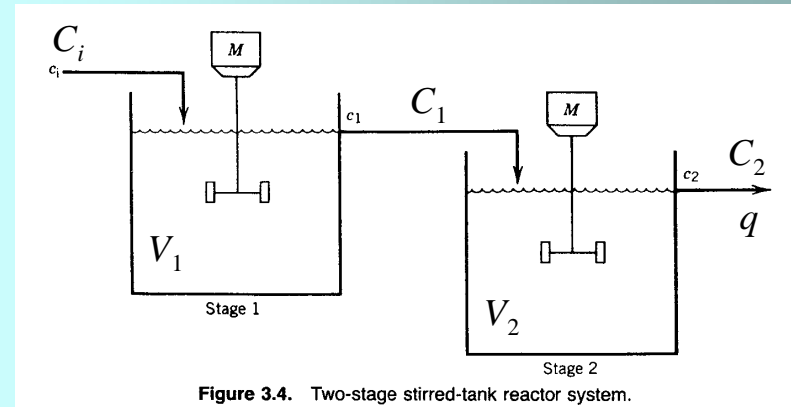
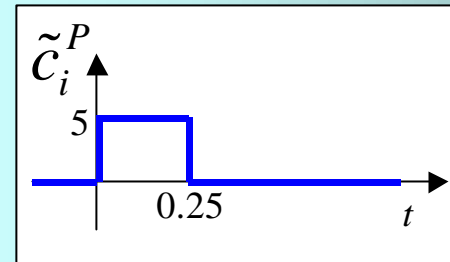

Figure 3.4. Two-stage stirred-tank reactor system.

- **Pulse input**

$$\tilde{C}_i^P(s) = \frac{5}{s} (1 - e^{-0.25s})$$



- **Equivalent impulse input**

$$\tilde{C}_i^d(s) = \mathcal{L}\{(5 \times 0.15)d(t)\} = 1.25$$

- **Pulse response vs. Impulse response**

$$\tilde{C}_1^P(s) = \frac{1}{2s+1} \tilde{C}_i^P(s) = \frac{5}{s(2s+1)} (1 - e^{-0.25s})$$

$$= \left(\frac{5}{s} - \frac{10}{2s+1} \right) (1 - e^{-0.25s})$$

$$\Rightarrow \tilde{c}_1^P(t) = 5(1 - e^{-t/2}) - 5(1 - e^{-(t-0.25)/2})S(t-0.25)$$

$$\tilde{C}_1^d(s) = \frac{1}{2s+1} \tilde{C}_i^d(s) = \frac{1.25}{(2s+1)}$$

$$\Rightarrow \tilde{c}_1^d = 0.625e^{-t/2}$$

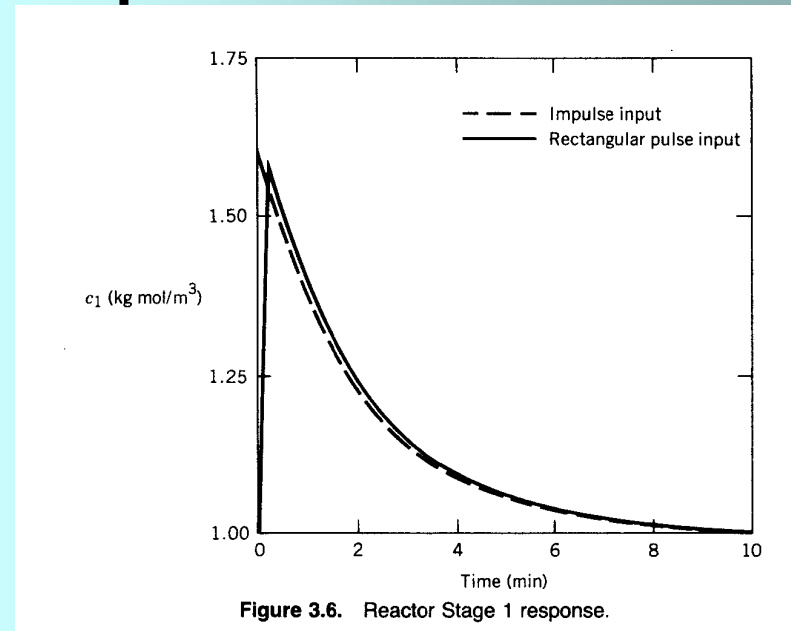

Figure 3.6. Reactor Stage 1 response.

$$\tilde{C}_2^P(s) = \frac{1}{(2s+1)(1.5s+1)} \tilde{C}_i^P(s) = \frac{5}{s(2s+1)(1.5s+1)} (1 - e^{-0.25s})$$

$$= \left(\frac{5}{s} - \frac{40}{2s+1} + \frac{22.5}{1.5s+1} \right) (1 - e^{-0.25s})$$

$$\Rightarrow \tilde{c}_2^P(t) = (5 - 20e^{-t/2} + 15e^{-t/1.5}) - (5 - 20e^{-(t-0.25)/2} + 15e^{-(t-0.25)/1.5}) S(t - 0.25)$$

$$\tilde{C}_2^d(s) = \frac{1}{(2s+1)(1.5s+1)} \tilde{C}_i^d(s)$$

$$= \frac{1.25}{(2s+1)(1.5s+1)}$$

$$= \frac{5}{2s+1} - \frac{3.75}{1.5s+1}$$

$$\Rightarrow \tilde{c}_2^d = 2.5e^{-t/2} - 2.5e^{-t/1.5}$$

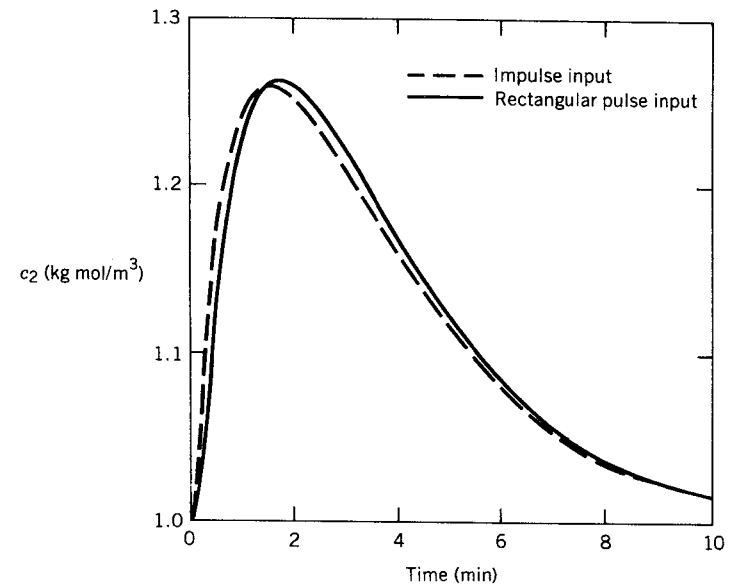

Figure 3.7. Reactor Stage 2 response.